

# 1000 Series Service Manual

## Templates

### Preparation of 200 Series Trim for Mortise

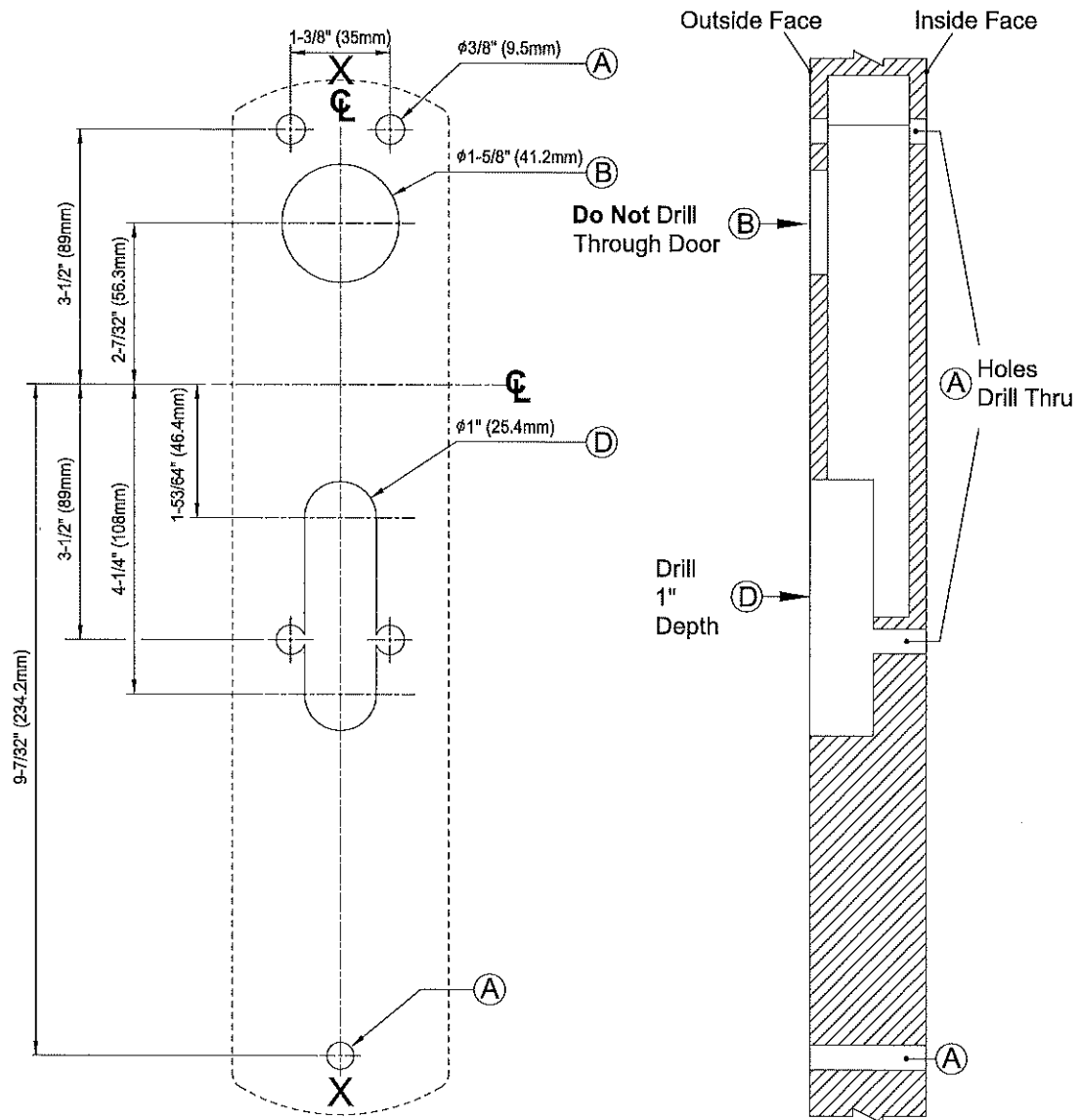

Device Type	Mortise		
Cut Out Illustration			
Description	203M	205M	215M
Function	03	05	15
Preparation	A+B	A+B+D	A+D

# 200 SERIES THUMBPIECE TRIM FOR EXIT DEVICE INSTALLATION INSTRUCTIONS

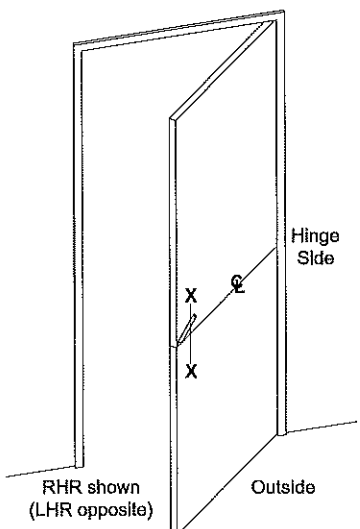

1. Prepare door for exit device. See exit device instructions for holes, backset (line X-X), and center lines.

2. Transfer line X-X from inside (exit device) side of door to outside (trim side) of door. Use extra care if edge of door is beveled. Be sure line X-X is parallel to edge of door.

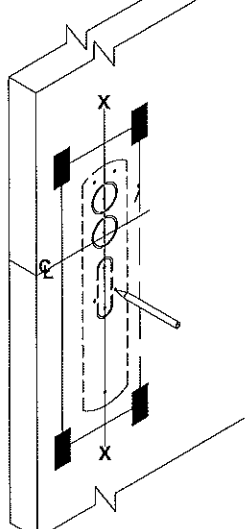

3. Locate X-X line and prepare required holes with template.

**NOTE:** See "APPLICATION CHART" on back page for different trim functions.

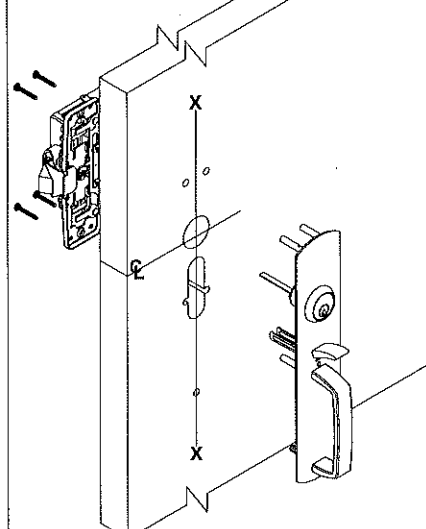

4. Determine trim handing and assemble trim. (see "INSTALL CYLINDER")

## INSTALL CYLINDER

### RIM CYLINDER FOR RIM AND VERTICAL ROD DEVICES

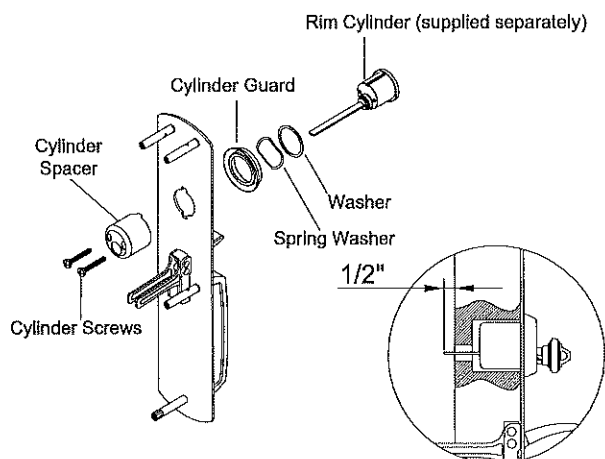

1. Mount rim cylinder to cylinder spacer and attach to outside trim with two(2) cylinder screws.
  2. Make sure the tailpiece is extending 1/2" from the inside face of door.
- NOTE:** Cut off tailpiece for different door ranges and various cylinder lengths.

### MORTISE CYLINDER FOR MORTISE DEVICE

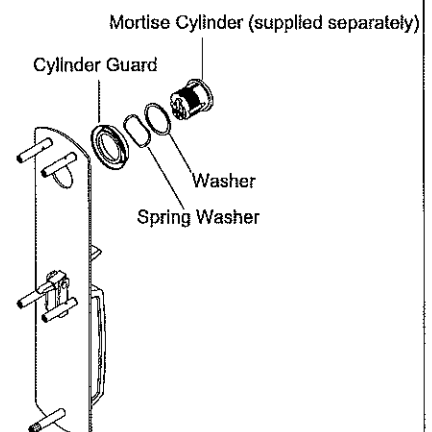

Mount mortise cylinder to mortise case.

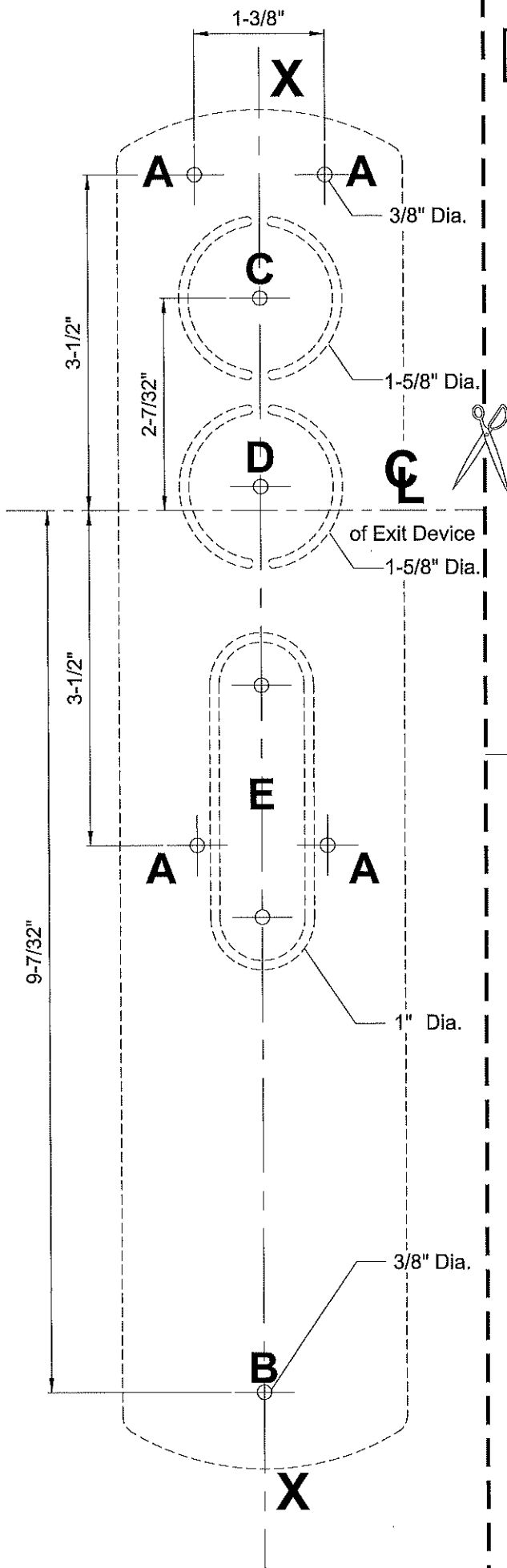

## DOOR PREPARATION

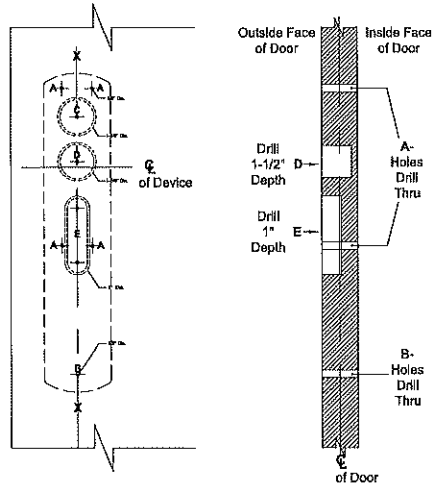

### FOR RIM AND VERTICAL ROD APPLICATION

CUT OUT ILLUSTRATION	201/202	203R	205R	215R
TRIM DESCRIPTION	201/202	203R	205R	215R
FUNCTION	01/02	03	05	15
PREPARATION	A+B	A+B+D	A+B+D+E	A+B+E

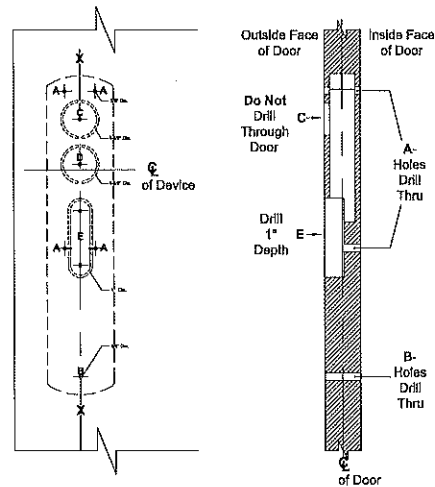

### FOR MORTISE LOCK APPLICATION

CUT OUT ILLUSTRATION	201/202	203M	205M	215M
TRIM DESCRIPTION	201/202	203M	205M	215M
FUNCTION	02	03	05	15
PREPARATION	A+B	A+B+C	A+B+C+E	A+B+E

Patent No. 7,634,927 7,748,757  
D623,499 7,836,738 7,887,107  
and other patents pending.