

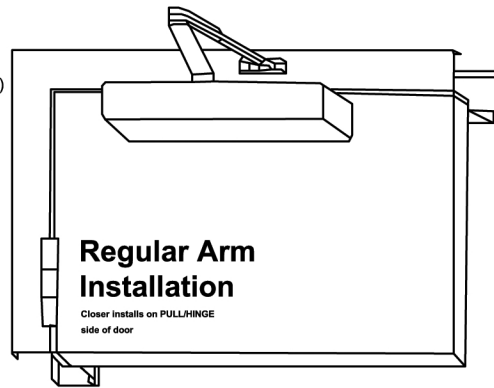

Surface mounted  
Adjustable & preset "Back-check"  
QDC 70 series  
No Hold-open/Hold-open  
Optional BF/DA

## Installation Instructions for REGULAR ARM (PULL SIDE) Mounting

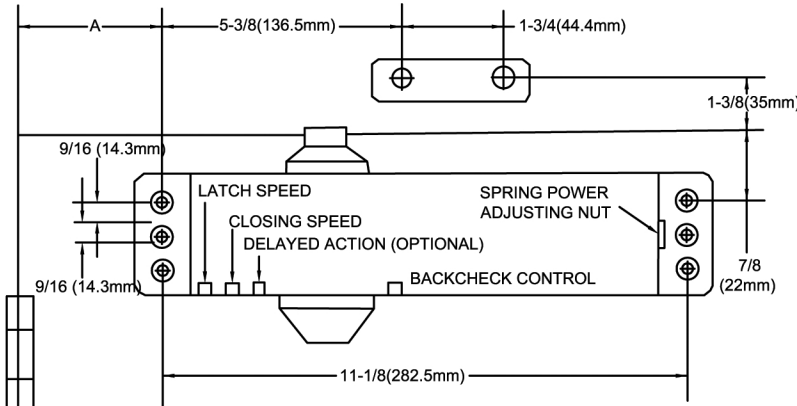

Hinge or Pivot

Opening Angle	Dimension A
0-85°	10-3/8" (263.5mm)
0-100°	9-1/16" (230mm)
0-110°	8-1/4" (210mm)
0-120°	7-3/32" (180mm)
120°-180°	3-15/16" (100mm)

- Right hand door shown
- Left hand door opposite
- Dimensions are in inches
- Do not scale drawing

### INSTALLATION INSTRUCTIONS

1. Select degree of opening from table and use template dimensions shown in above, mark six(6) holes on door for door closer and two (2) holes on frame for arm shoe.
2. Drill pilot holes in door and frame for #14 all-purpose screws or drill and tap for 1/4-20 machine screws.
3. Install adjustable forearm/arm shoe assembly to frame using screws provided.
4. Install main arm to top pinion shaft using screw provided.
5. Mount closer on door using screws provided. SPRING POWER ADJUSTING NUT MUST BE POSITIONED AWAY FROM HINGE EDGE.
6. Adjust length of adjustable forearm so that adjustable forearm is perpendicular to frame when assembled
7. Snap pinion cap over shaft at bottom of closer. (When using full cover, pinion cap is not necessary)
8. Adjust closing speed, back check control and spring power of door, following instructions as shown page 4.

## Top View Typical Installation

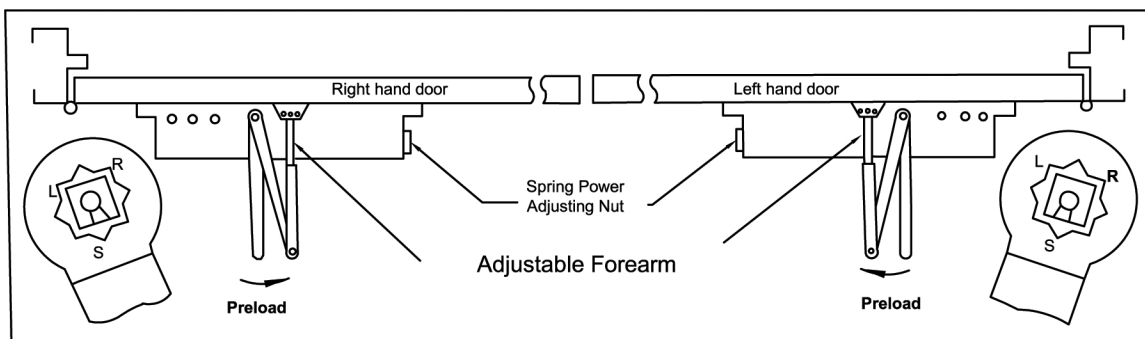

13097 Parkside Dr., Suite B, Fishers, IN 46038 • Phone: 317-806-1180 • Fax: 317-578-2904

www.marshallbestsecurity.com



Surface mounted  
Adjustable & preset "Back-check"  
QDC 70 series  
No Hold-open/Hold-open  
Optional BF/DA

## Installation Instruction for TOP JAMB (PUSH SIDE) Mounting

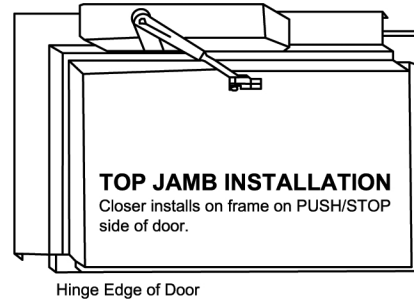
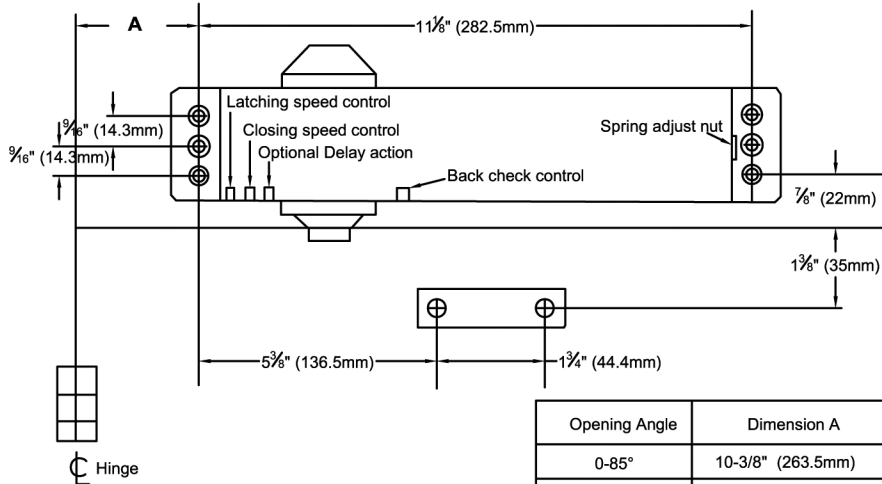

Opening Angle	Dimension A
0-85°	10-3/8" (263.5mm)
0-100°	9-1/16" (230mm)
0-110°	8-1/4" (210mm)
0-120°	7-3/32" (180mm)
120°-180°	3-15/16" (100mm)

- Left hand door shown
- Right hand door opposite
- Dimensions are in inches
- Do not scale drawing

### INSTALLATION INSTRUCTIONS

1. Select degree of opening from table and use template dimensions shown in above, mark six (6) holes on door for door closer and two (2) holes on frame for arm shoe.
2. Drill pilot holes in door and frame for #14 all-purpose screws or drill and tap for 1/4-20 machine screws.
3. Install adjustable forearm/arm shoe assembly to frame using screws provided.
4. Install main arm to top pinion shaft using screw provided.
5. Mount closer body on frame using screw provided, SPRING POWER ADJUSTING NUT MUST BE POSITIONED AWAY FROM HINGE EDGE.
6. Adjust length of adjustable forearm so that adjustable forearm is perpendicular to door when assembled to preloaded main arm (illustration below). Secure forearm to main arm with screw provided.
7. Snap pinion cap over shaft on top of closer. (When using full cover, pinion cap is not necessary)
8. Adjust closing speed, backcheck control and spring power of door, following instructions as shown page 4.

## Top View Typical Installation

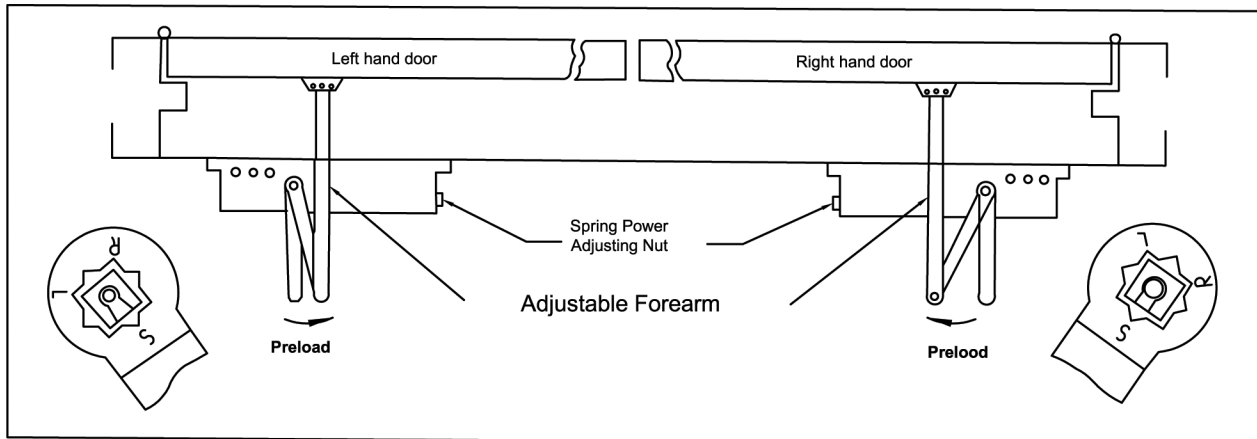

13097 Parkside Dr., Suite B, Fishers, IN 46038 • Phone: 317-806-1180 • Fax: 317-578-2904

www.marshallbestsecurity.com



Surface mounted  
Adjustable & preset "Back-check"  
QDC 70 series  
No Hold-open/Hold-open  
Optional BF/DA

## Installation Instructions for PARALLEL ARM(PUSH SIDE) Mounting

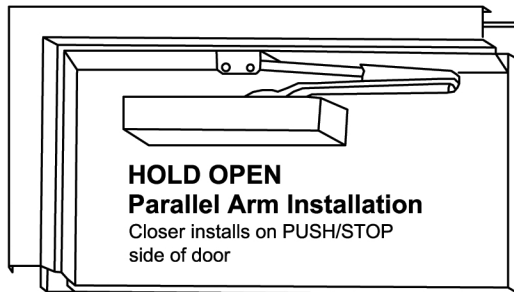
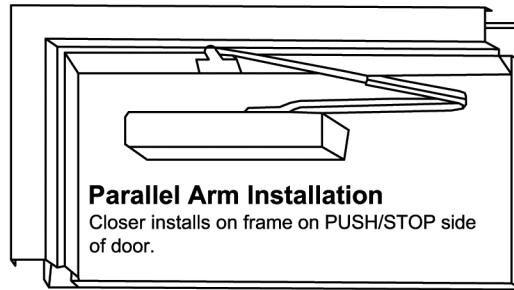
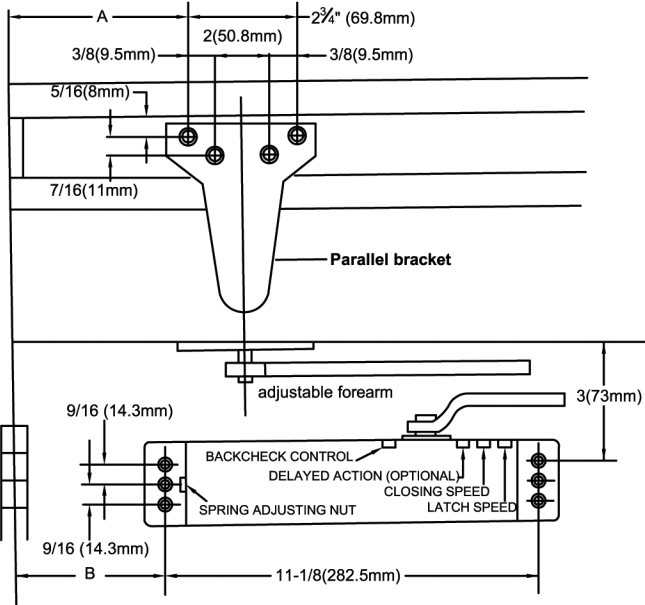

OPENING	DIM.A	DIM.B
TO 120°	9-1/8(241mm)	6-1/8(156mm)
120°-180°	5-7/8(149.2mm)	2-9/16(65mm)

- Left hand door shown
- Right hand door opposite
- Dimensions are in inches
- Do not scale drawing

### INSTALLATION INSTRUCTIONS

1. Select degree of opening from table and use template dimensions shown in above, mark six (6) holes on door for door closer and four (4) holes underside of frame for bracket.
  2. Drill pilot holes in door and frame for #14 all-purpose screws of drill and tap for 1/4-20 machine screws.
  3. Mount closer on door using screws provided. SPRING POWER ADJUSTING NUT MUST BE POSITIONED TOWARD HINGE EDGE.
  4. Install parallel Arm Bracket to frame using screws provided.
  5. Using a wrench on the square shaft at bottom of shaft on top of closer, rotate shaft approximately 45° toward hinge edge of door. Hold and place main arm of shaft on top of closer at proper index mark as illustrated.
- FOR LEFT HAND DOOR "L" (illustration "A"). FOR RIGHT HAND DOOR "R" (illustration "B"). Tighten arm screw with lock washer securely.
6. Remove arm shoe from the forearm and discard (arm shoe is not used for parallel installation) and tighten screw securely.
  7. Adjust length of adjustable forearm so that adjustable forearm is parallel to frame.
  8. Snap pinion cap over shaft at bottom of closer (when using full cover, pinion cap is not necessary)
  9. Adjust closing speed, backcheck control and spring power of door, following instruction as page 4.

### Top View Typical Installation

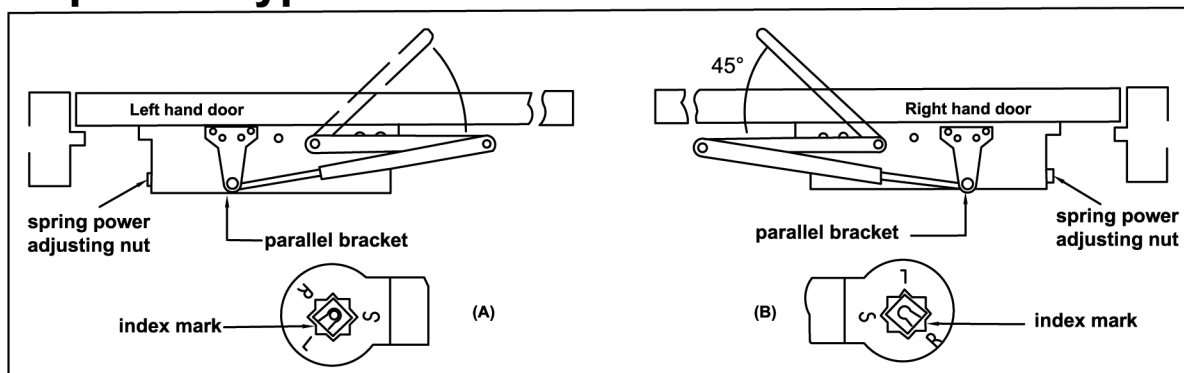



Surface mounted  
Adjustable & preset "Back-check"  
QDC 70 series  
No Hold-open/Hold-open  
Optional BF/DA

## CLOSER ADJUSTMENT

### CLOSING CYCLE

**NOTE:** Closing arcs ("CLOSE" and "LATCH") are controlled by two (2) speed adjusting valves. Adjust the CLOSING speed first, then adjust the LATCHING speed.

- "CLOSING" speed adjustment is accomplished by full rotations of the speed adjusting valve.
  - Turn the speed adjusting valve **CLOCKWISE** for a **SLOWER CLOSE** arc closing speed.
  - Turn the speed adjusting valve **COUNTER-CLOCKWISE** for a **FASTER CLOSE** arc closing speed.
- "LATCH" speed adjustment is accomplished by full rotations of the speed adjusting valve.
  - Turn the speed adjusting screw **CLOCKWISE** for a **SLOWER Latch** arc closing speed.
  - Turn the speed adjusting screw **COUNTER-CLOCKWISE** for a **FASTER Latch** arc closing speed.

**CAUTION!!** Do not turn speed adjusting more valve than two (2) full turns counter-clockwise from its factory set position, as two speed adjusting valves could become dislodged from the door closer body, resulting in the loss of internal fluid and failure of the device.

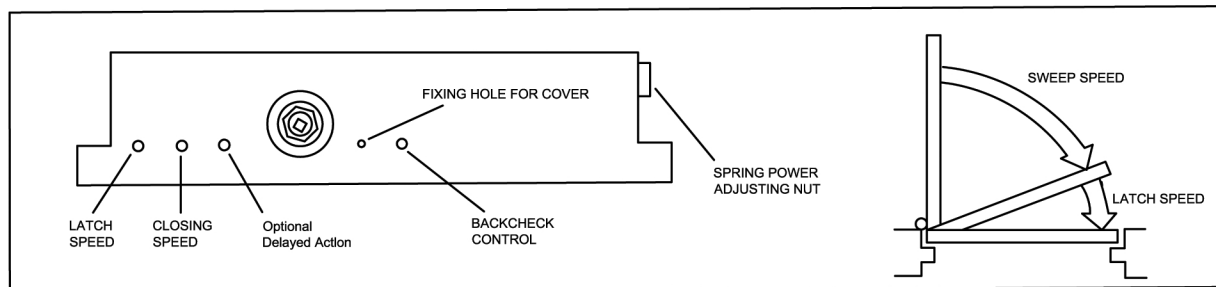

### BACK CHECK CONTROL

To increase back check intensity, turn back check control valve clockwise.

To decrease back check intensity, turn back check control valve anticlockwise.

### SPRING POWER CONTROL

To increase opening force and closing force, turn the spring adjusting nut clockwise.

To decrease opening force and closing force, turn the spring adjusting nut anticlockwise.

### FULLY ADJUSTABLE SPRING

QDC 70 SERIES CLOSERS ARE SHIPPED AS SIZE 3. ROTATE SPRING ADJUSTMENT NUT COUNTER CLOCKWISE 3 TURNS TO REDUCE TO SIZE 2. ROTATE SPRING ADJUSTMENT NUT CLOCKWISE TO INCREASE SPRING POWER. MAXIMUM 10 TURNS TO ATTAIN SIZE 6.

CLOSER SIZE		CLOCKWISE TURNS OF ADJUSTING NUT
BC/DA	BF	
1	1/2	-3*
2	1	0
3	2	3
4	3	6
5	4	9

\*-3 = 3 TURNS COUNTERCLOCKWISE

### OPENING CYCLE

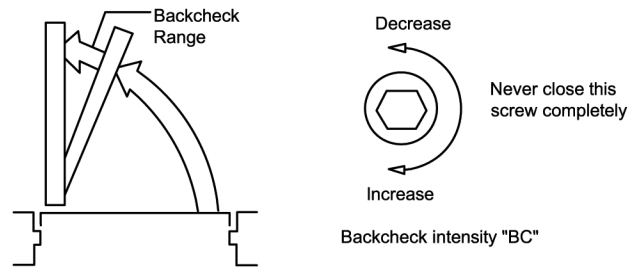

### ADJUSTABLE SPRING MODELS

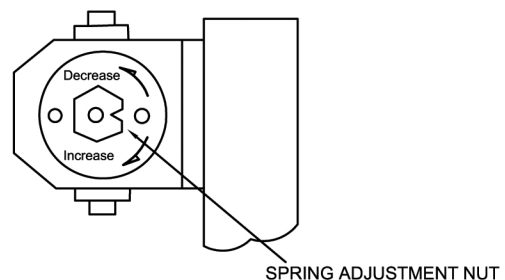

**NOTE:** MAXIMUM ADJUSTMENT IS APPROXIMATELY 10 TURNS. DO NOT FORCIBLY EXTEND ADJUSTMENT BEYOND LIMITS.



13097 Parkside Dr., Suite B, Fishers, IN 46038 • Phone: 317-806-1180 • Fax: 317-578-2904

www.marshallbestsecurity.com