

**1200/F1200 SERIES
SURFACE VERTICAL ROD DEVICE**

INSTALLATION INSTRUCTIONS

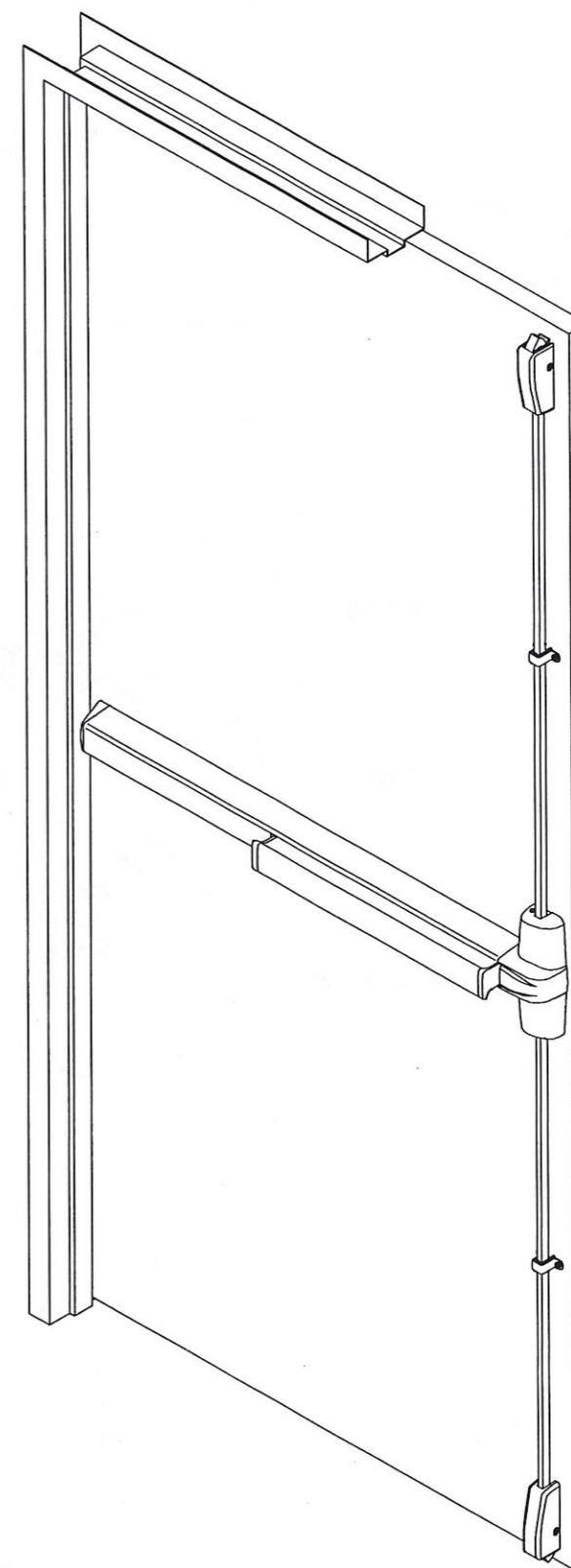

Patent No. 7,634,927 7,748,757
D623,499 7,836,738 7,887,107
and other patents pending.

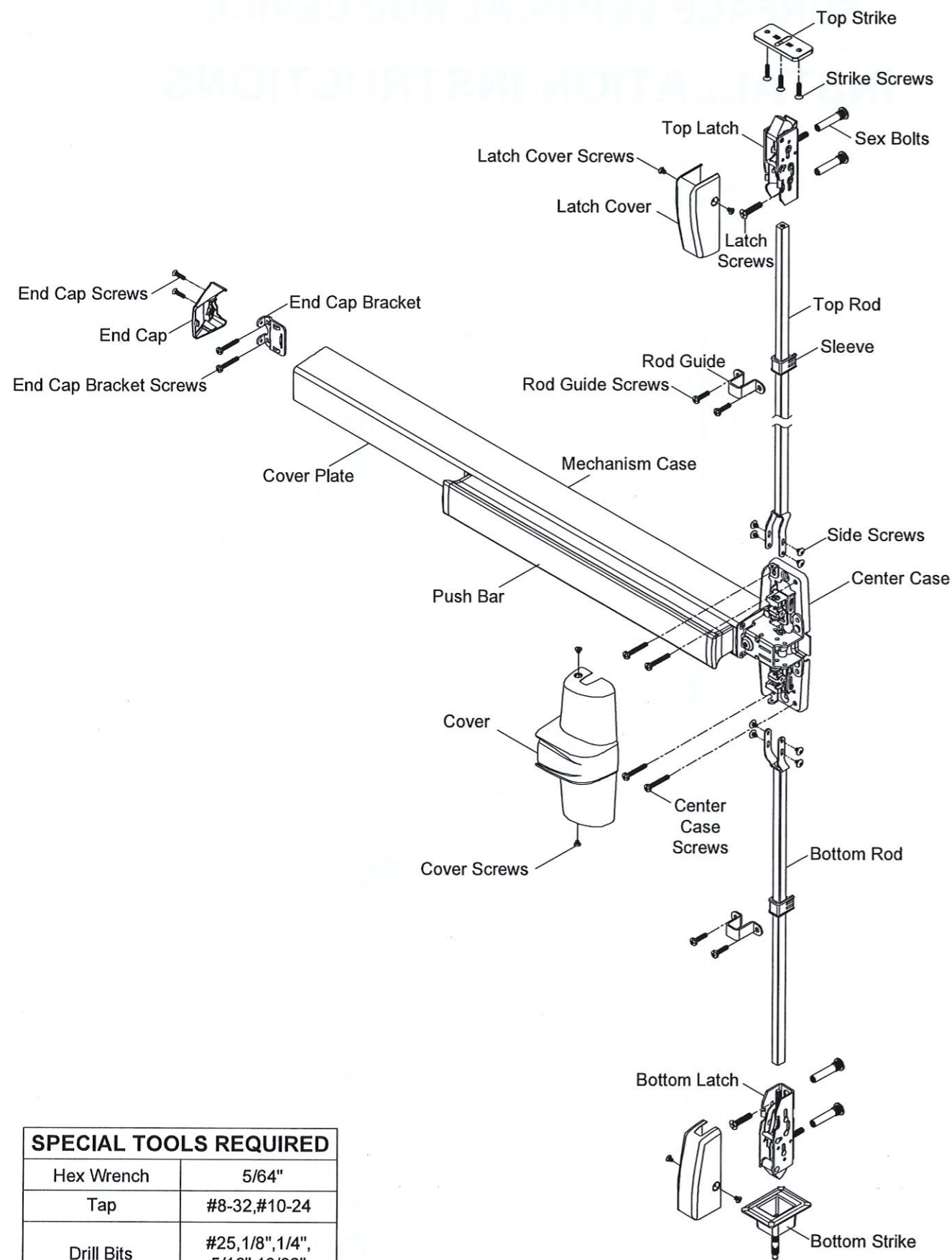

SPECIAL TOOLS REQUIRED	
Hex Wrench	5/64"
Tap	#8-32, #10-24
Drill Bits	#25, 1/8", 1/4", 5/16", 13/32"
Spade Drill	5/8" (For Wood Door)

OPTIONAL DOGGING

CYLINDER DOGGING

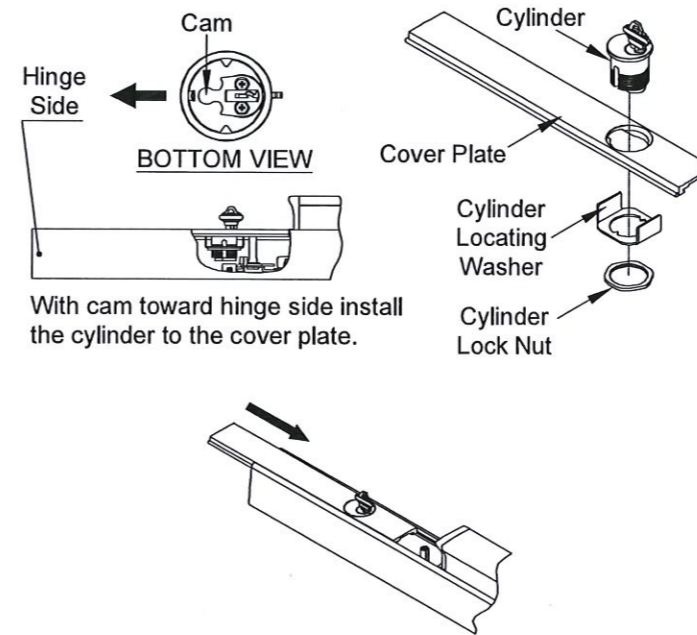

Slide cover plate in position in the mechanism case.

DOGGING CHECK

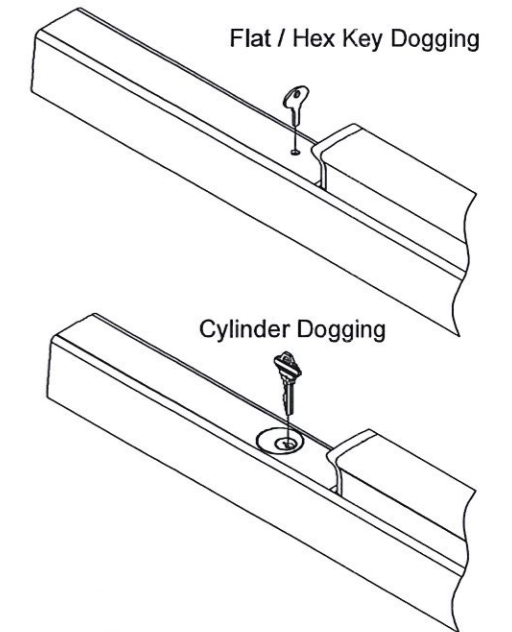

Depress push bar and turn flat / hex wrench or key one full turn for dogging check.

CUT DEVICE (IF REQUIRED)

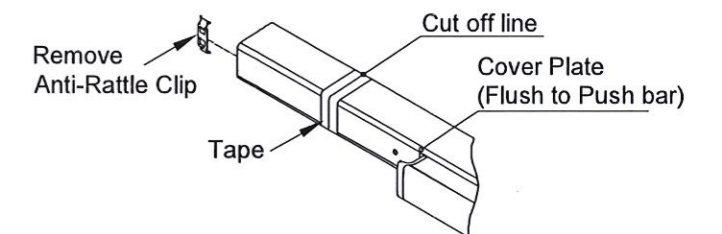
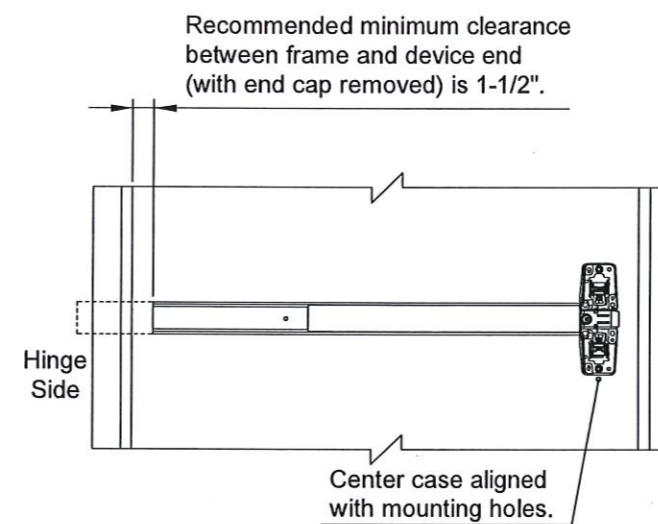

1. With anti-rattle clip removed, tape and mark area being cut.

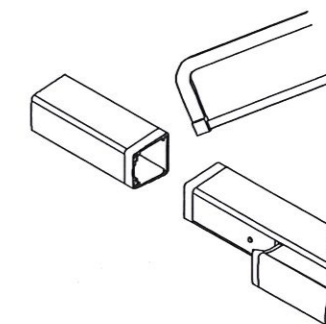

2. Cut off device and deburr.
NOTE: Device must be cut square for proper end cap fit.

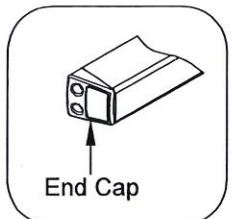

INSTALL FIRE BOLT

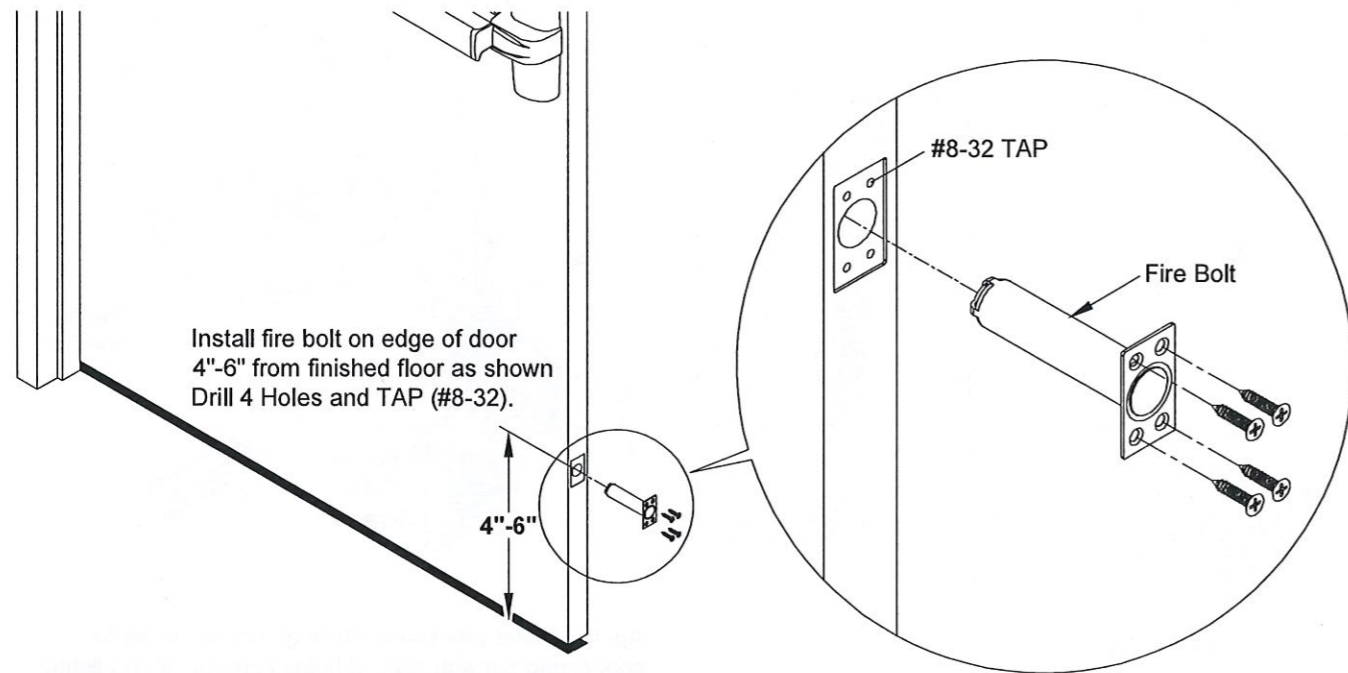

NOTE: Fire rated device with less bottom rod (LBR) applications must use FIRE BOLT.

CUT TOP ROD / EXTEND TOP ROD

CUT TOP ROD

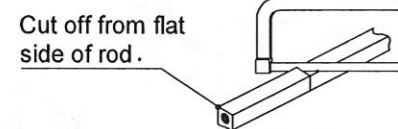

Step 1: Make sure the flat side of rod, and measure amount to cut off rod.
NOTE: Rod cutting is required for doors shorter than 7'.



EXTEND TOP ROD

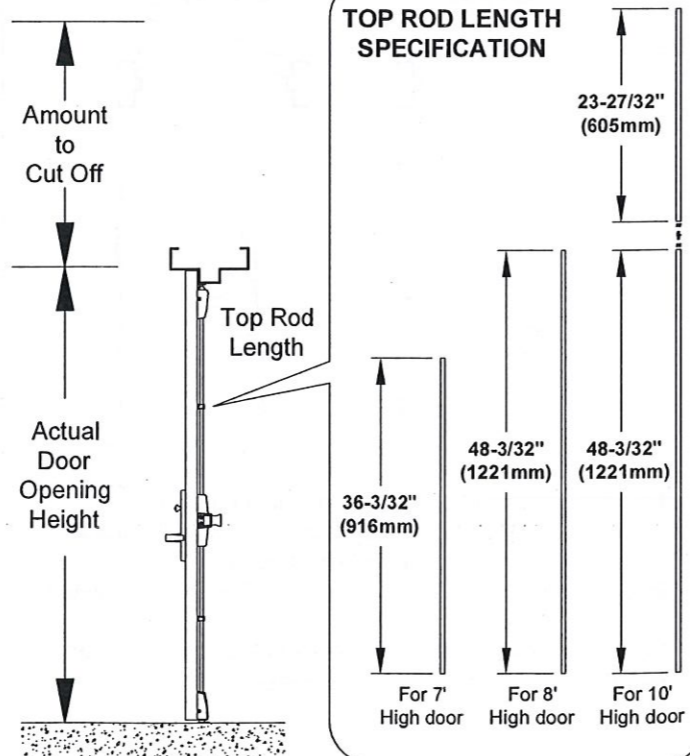
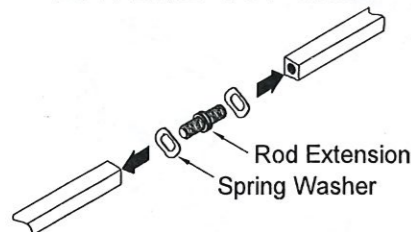

SCREW CHART

APPLICATION	METAL	SEX BOLTS	WOOD
Center Case Screws	C No.10-24 x 1-11/32" 4 PCS	C No.10-24 x 1-11/32" 4 PCS G No.10-24 x 1-3/32" 4 x PCS	A No.10-12 x 1-11/32" 4 x PCS
End Cap Bracket Screws	C No.10-24 x 1-11/32" 2 PCS	C No.10-24 x 1-11/32" 2 PCS G No.10-24 x 1-3/32" 2 x PCS	A No.10-12 x 1-11/32" 2 x PCS
Rod Guide Screws	D No.10-24 x 25/32" 2 x PCS		A No.10-12 x 1-11/32" 2 x PCS
224 / 225 Strike Screws	E No.10-24 x 11/16" 2 x PCS		
Top / Bottom Latch Screws		F No.1/4-20 x 1-1/6" 1 x PCS H No.1/4-20 x 1-3/32" 2 x PCS	
106 / 215 Strike Screws	E No.10-24 x 11/16" 3 PCS		B No.10-12 x 1-11/32" 3 PCS
108 Strike Screws	E No.10-24 x 11/16" 7 PCS		B No.10-12 x 1-11/32" 7 PCS
227 Strike Screws	N No.1/4-20 x 5/8" 1 PCS	O No.1/4-20 x 5/8" 1 PCS	
Side Screws & Connecting Screws	F No.1/4-20 x 1-1/6" 1 PCS	L No.8-32 x 7/32" 4 PCS	
End Cap Screws	J	No.8-32 x 5/8" 2 PCS	
Cover Screws	I	No.8-32 x 5/32" 2 PCS	

DOOR PREPARATION CHART

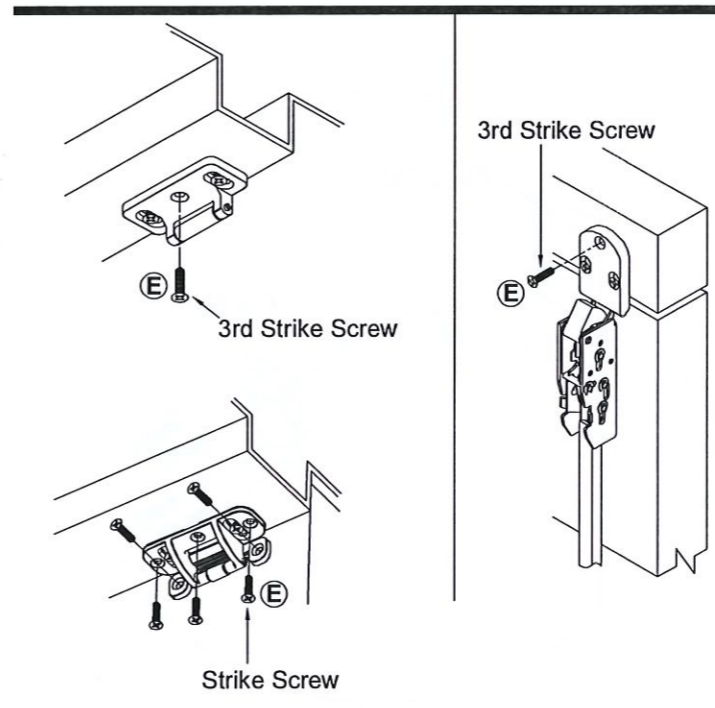
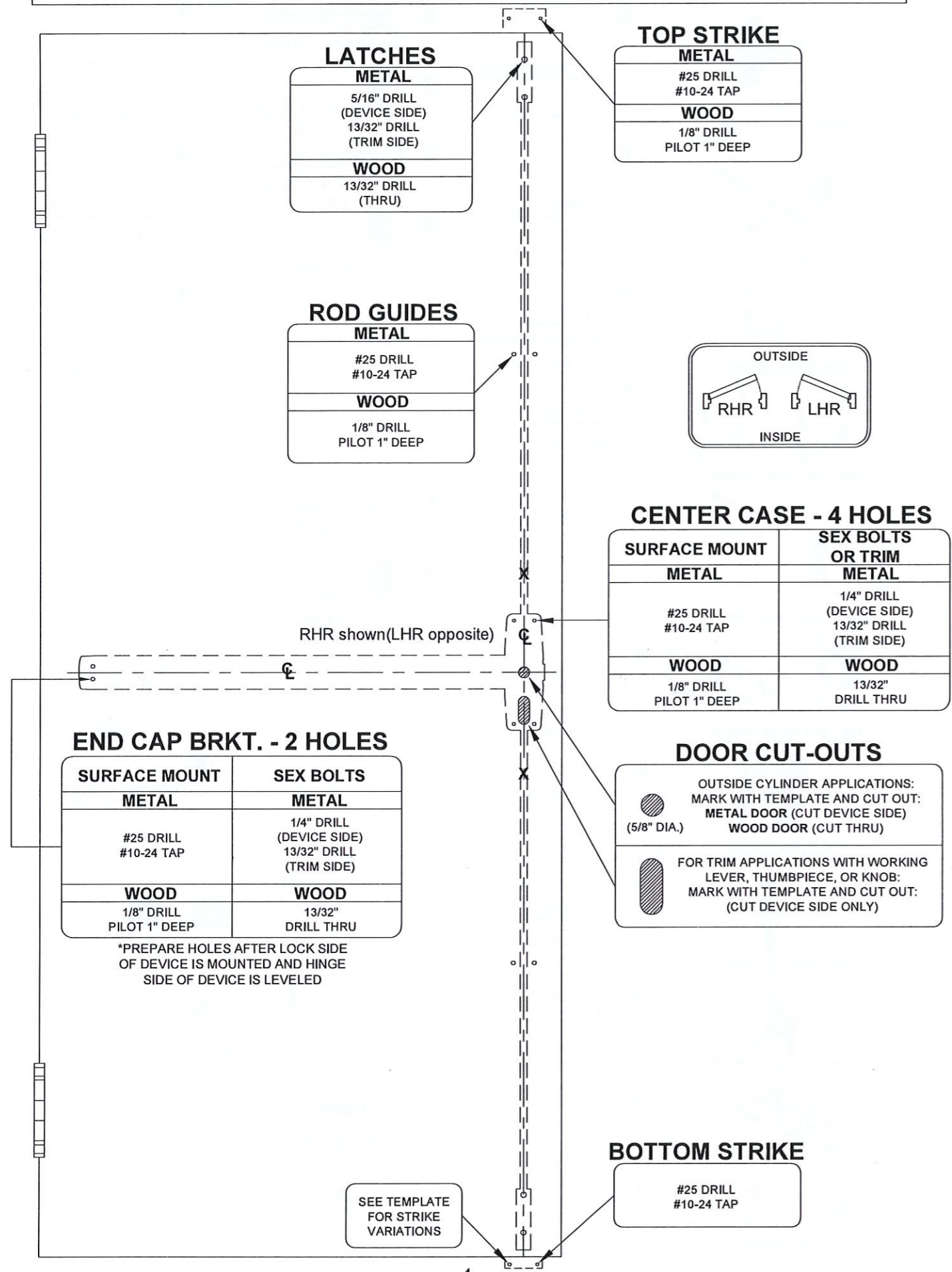

3. Apply third screw in hole of strike once adjustment is complete.

13 ADJUST BOTTOM ROD WITH DOOR OPEN (TOP LATCH RETRACTED).

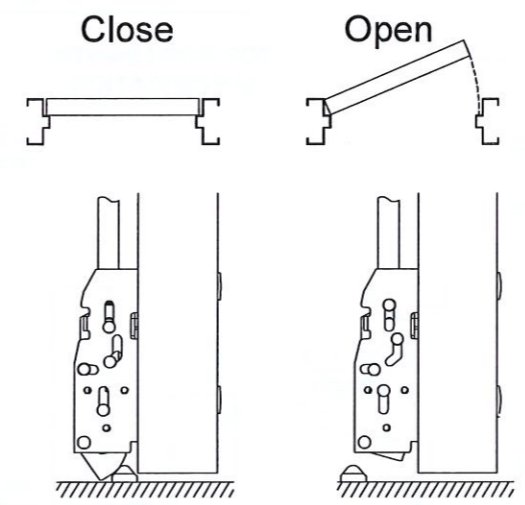

1. Place device in holdback by pushing on push bar. Bottom latch bolt clears bottom strike, adjust retractor by screw driver or readjust rod if needed.
2. Secure two side screws when adjustment is completed.

Open and close door a few times and check for deadlocking when door is closed.

11 SECURE TWO(2) SIDE SCREWS.

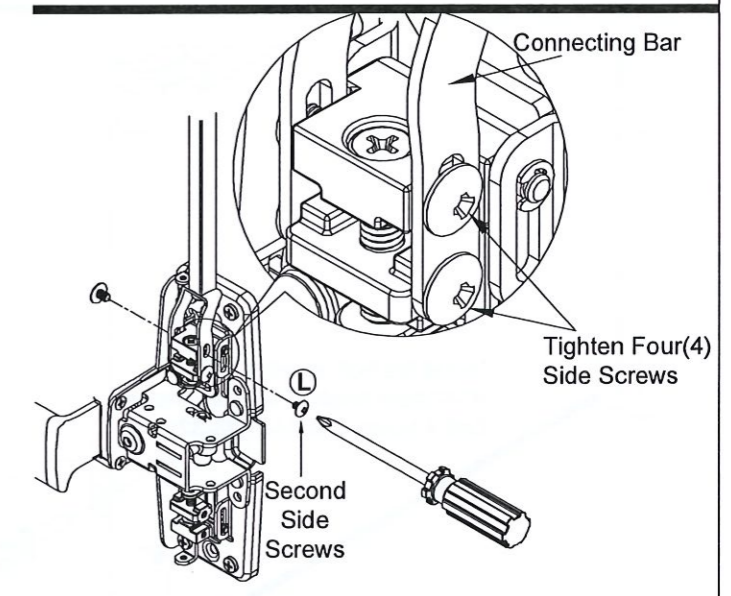

Apply second side screws through second holes in connecting bar with second holes in retractor and tighten two side screws.

14 INSTALL ROD GUIDES AND COVERS WITH SCREWS.

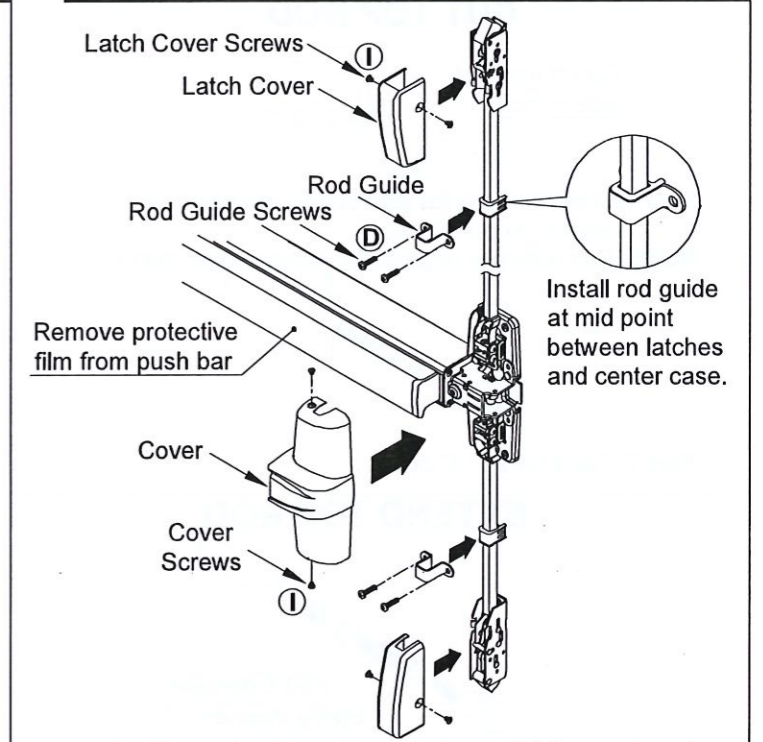

Position rod guides midway between latches and center case, centered on rods. Mark, drill/tap and fasten rod guides with two(2) screws.

10 CHECK TOP LATCH FOR HOLDBACK AND DEADLOCK.

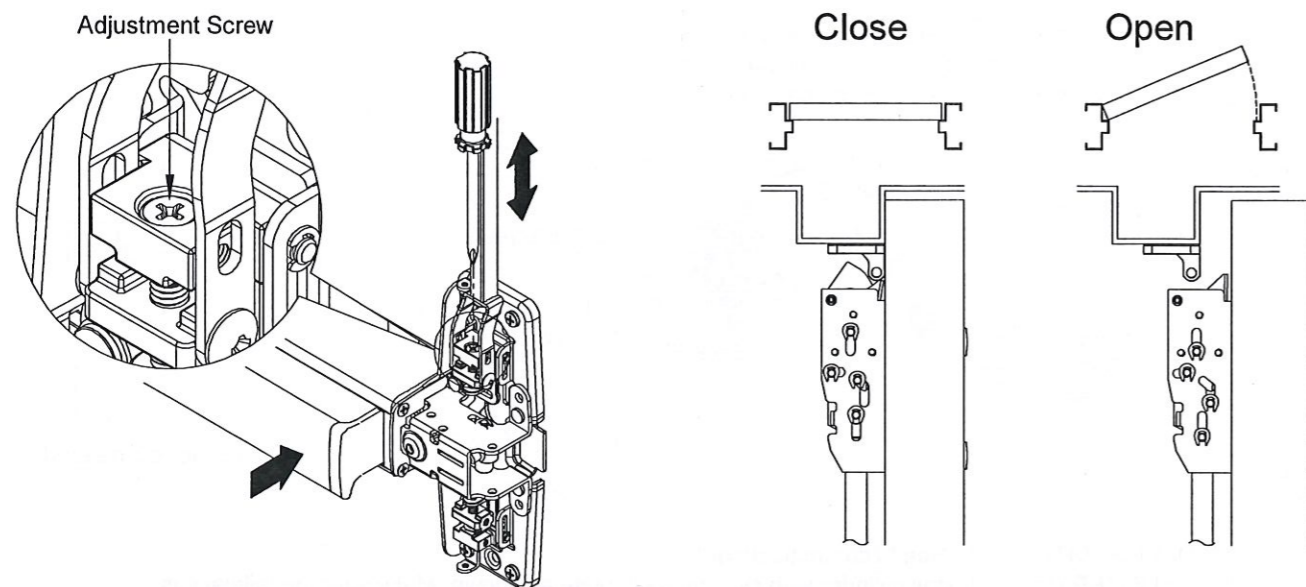

1. Pushing on push bar will retract the latchbolt and open the door. Latchbolt will stay retracted and device is in **HOLDBACK**. If **NO HOLDBACK** adjust the screw in top of retractor by screw driver.

2. Fully extended latchbolt should be in **DEADLOCK**. **DEADLOCKED** latchbolt cannot be pushed down into the latch housing. If **NO DEADLOCK**, loose strike screws and adjust strike position.

12 INSTALL BOTTOM LATCH AND ROD.

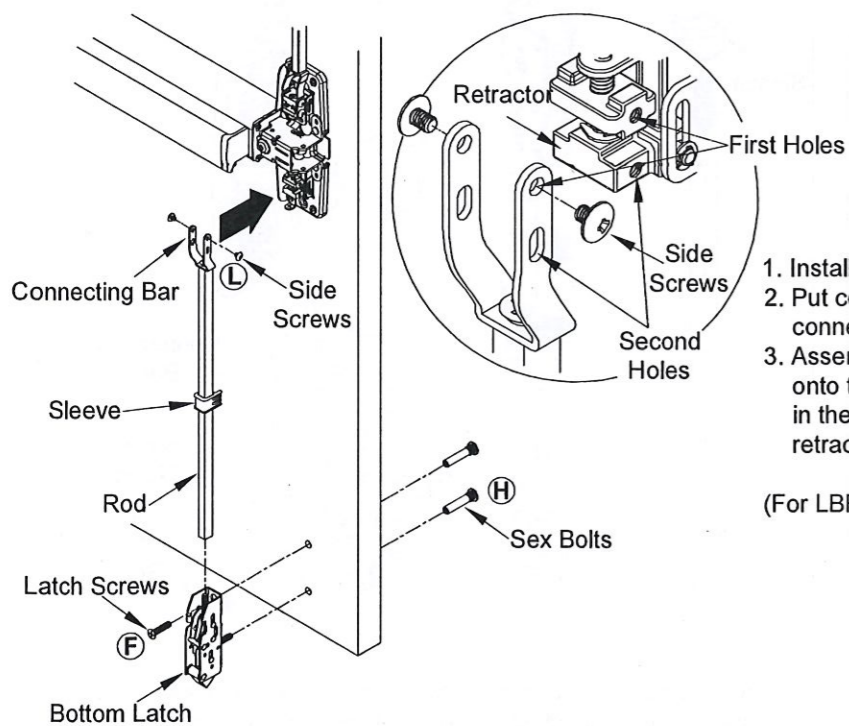

1. Install bottom latch with two(2) screws(Sex bolts).
2. Put connecting screw through round hole of connecting bar and thread into bottom rod and tighten.
3. Assemble sleeve with rod, thread the bottom rod onto the stud in the bottom latch until the first holes in the end of connecting bar align with first holes in retractor and fasten side screws.

(For LBR devices omit preparation for bottom Latch and rod.)

1 DRAW HORIZONTAL CENTERLINE (C).

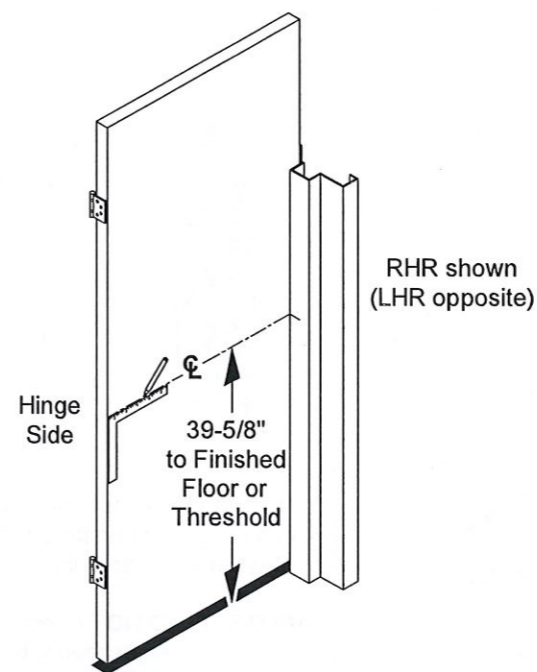

Mark horizontal centerline on inside face of door 39-5/8" from finished floor as shown. (Continue horizontal center line to outside face of door if trim is used)

3 ALIGN TOP & BOTTOM TEMPLATES ALONG CENTERLINE, THEN MARK AND PREPARE DOOR.

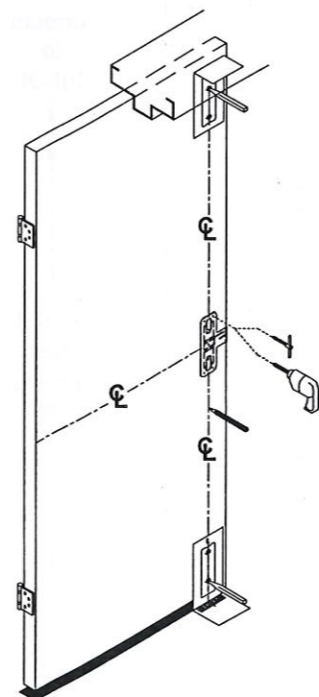

1. Fold strike template and place on door stop and inside face of door, so the vertical centerline on template lines up with the vertical centerline on door stop and door.
2. Tape template on door stop and the door face.
3. Mark centers and drill/tap holes as indicated on the template. See "DOOR PREPARATION CHART" on page 4 for drill/tap, and cut-out information.

2 POSITION TEMPLATE AS SHOWN AND MARK VERTICAL C.

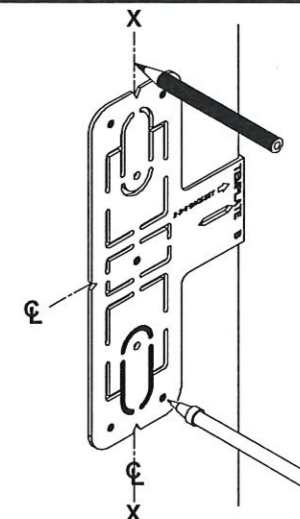

Mark vertical center line X-X above and below horizontal center line. (Mark vertical center line at lock side using same backset dimension on outside face of door if trim is using). **CAUTION:** Vertical center lines on both sides of the door should be the same dimension from the edge of the door. Use extra care if edge of door is beveled. Be sure X-X vertical center line is parallel to edge of door.

4 INSTALL TOP STRIKE AND SHIM.

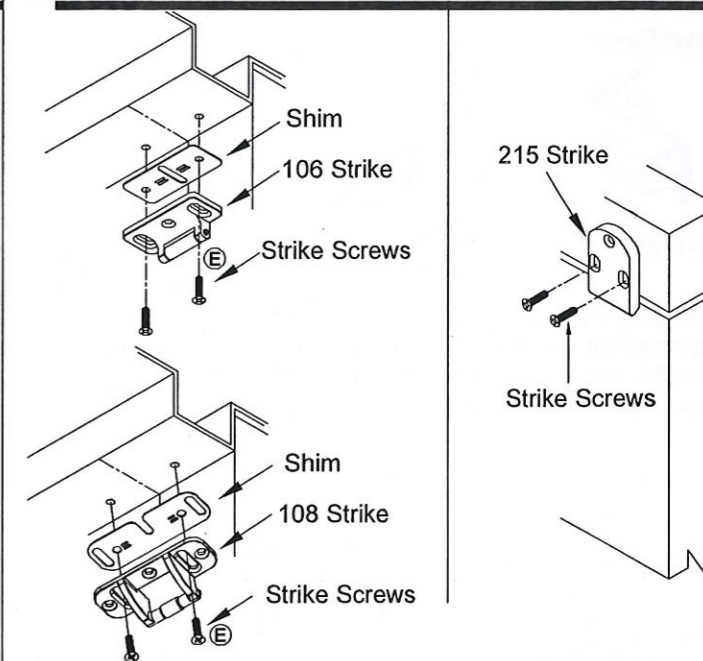

Install a screw through each slot.

5 INSTALL BOTTOM STRIKE.

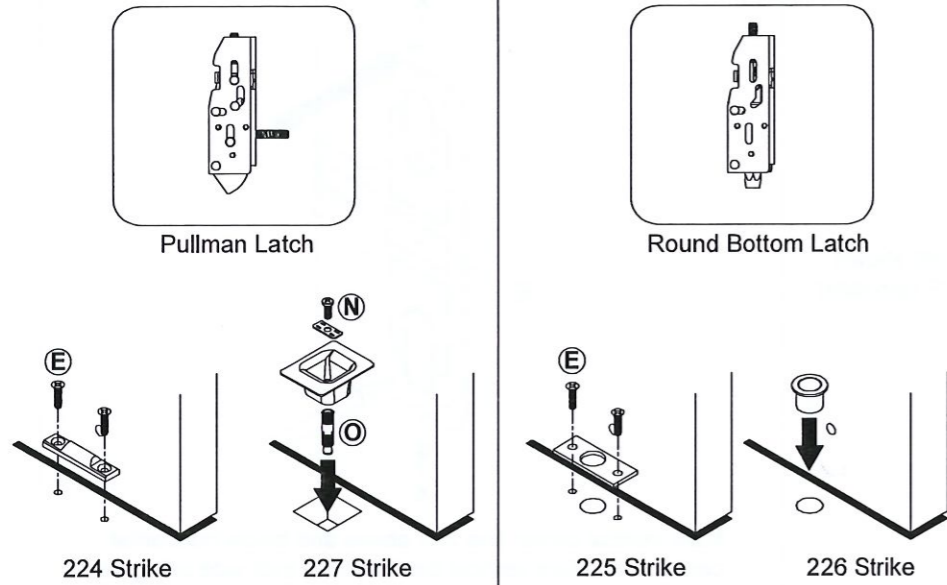

1. Mark floor for fasteners, prepare floor according to the type of strike and fastener furnished. Provide clearance in floor for bolt.
2. For threshold application:
Provide hole in threshold according to type of strike and fasteners furnished.

6 DETERMINE USE OF NL DRIVE SCREW.

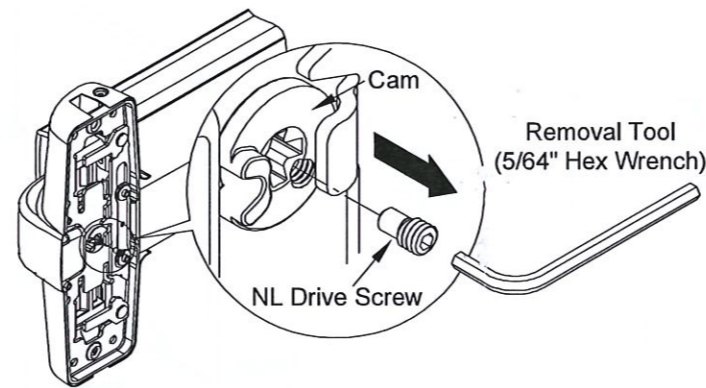

NL driver screw is factory assembled in cam on back of device center case, when the NL drive screw is left in back of center case, the outside cylinder will function only as a Night Latch.

- NOTE:**
1. **DO NOT** remove NL drive screw for Pull Plate or Escutcheon with night latch cylinder.
 2. **REMOVE** NL drive screw from back of center case when installing trim that has a functional lever, knob, or thumbpiece **AND** an outside cylinder to lock and unlock the trim.

7 INSTALL TRIM (IF USING) AND SECURE DEVICE CENTER CASE TO DOOR.

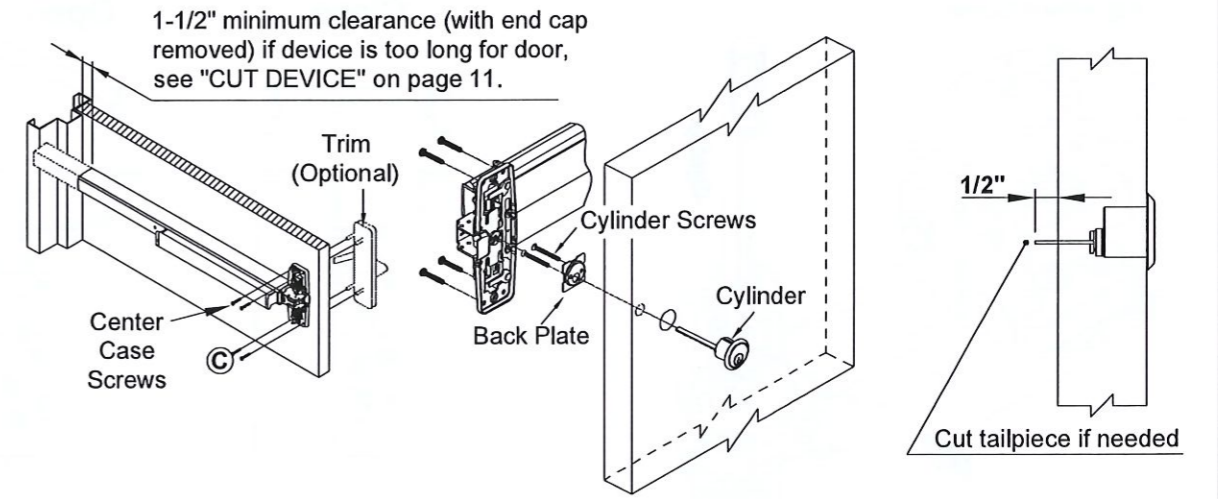

1. **DEVICE WITH TRIM** - See "Trim Instructions".
2. **CYLINDER ONLY** - Install cylinder with cylinder back plate as shown. Make sure the tailpiece is extending 1/2" from the inside face of door. Insert tailpiece into cam in the center case and mount it to the door with four(4) center case screws.
3. **EXIT ONLY** - Mount center case to the door with four(4) center case screws.

8 INSTALL MOUNTING BRACKET AND END CAP.

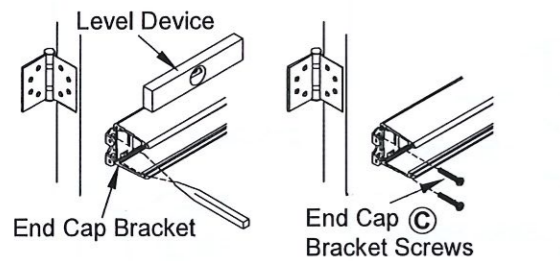

1. Remove cover plate, insert end cap bracket into push bar assembly against mechanism case. Level device, mark and drill two(2) holes for Bracket Screws. Fasten end cap bracket screws to door.

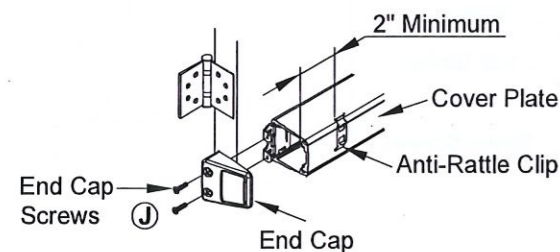

2. Insert cover plate, slide anti-rattle clip in position (2" minimum from end), and attach end cap with two(2) end cap screws.

9 INSTALL TOP LATCH AND ROD.

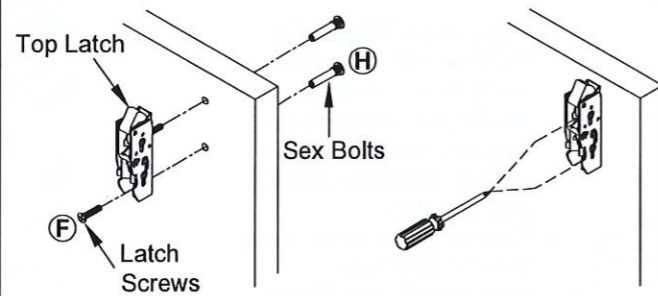

Figure 1

1. Install top latch with two(2) screws (sex bolts). Adjust strike so that device latches without binding. **See Figure 1**
2. Determine rod lengths as shown in **Figure 2**. If necessary; cut end of rod and tap. See "CUT TOP ROD / EXTEND TOP ROD" on page 10.

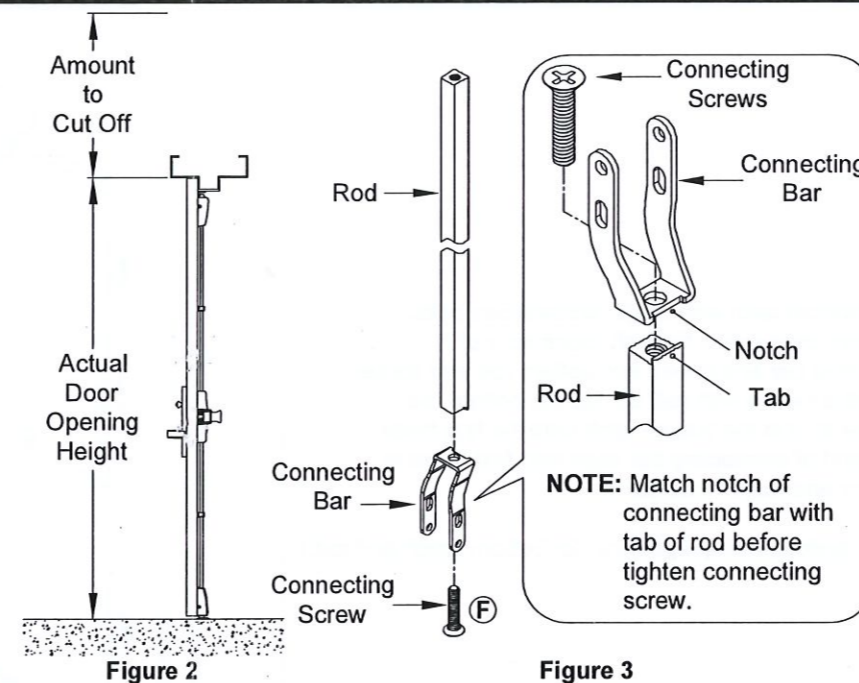
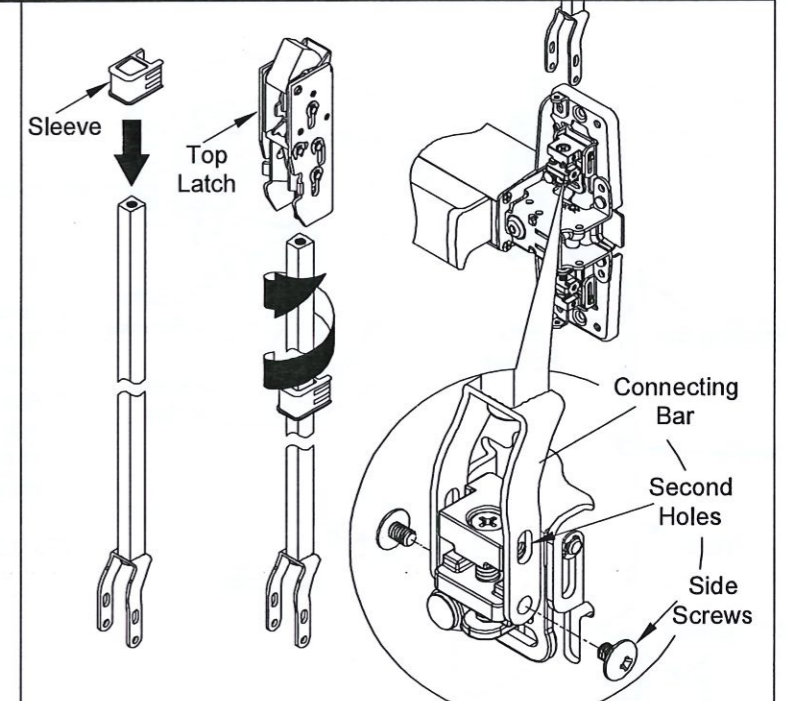

Figure 2

Figure 3

3. Put connecting screw through round hole of connecting bar and thread into top rod and tighten. **See Figure 3**



4. Assemble sleeve with rod. Thread top rod onto top latch until first hole in connecting bar align with first hole in retractor and fasten side screws.