

HOW TO INSTALL THIS CYLINDRICAL LEVER LOCK

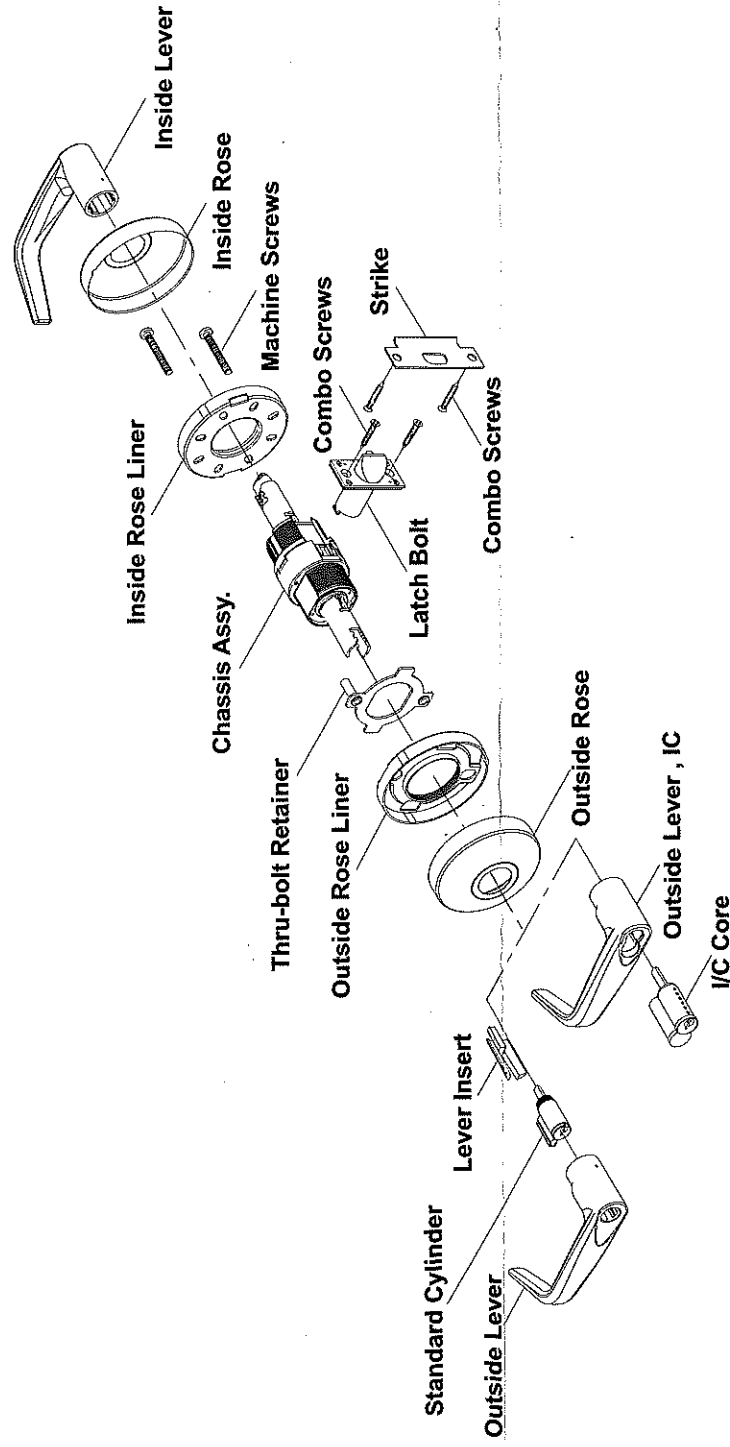

1. MARK DOOR

- Mark height line on edge of door approximately 38" from floor.
- Using the proper backset, mark 2 1/8" hole on both sides of the door.
- Mark 5/16" holes, two places on outside of the door.
- Mark the center of the door edge for the latch.

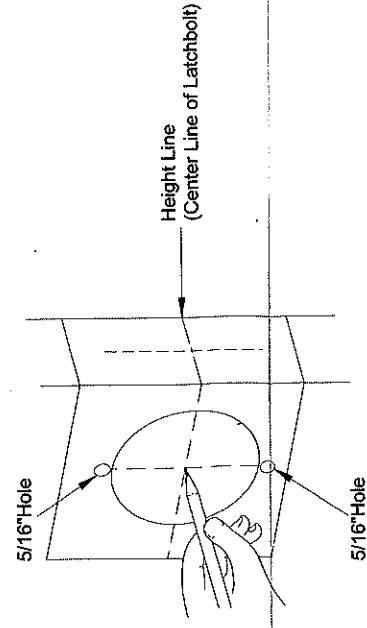

2. DOOR PREPARATION

- Bore 2 1/8" hole thru and two 5/16" holes from both sides of door to prevent splintering door finish.
- Bore 1" hole for latch on door.
- Using the latch faceplate as a guide, trace outline and mortise door edge so latch is flush with door.
- Install latch with screws provided

NOTE: Hollow metal doors must be properly reinforced for lock support (if support was not furnished, contact door manufacturer).

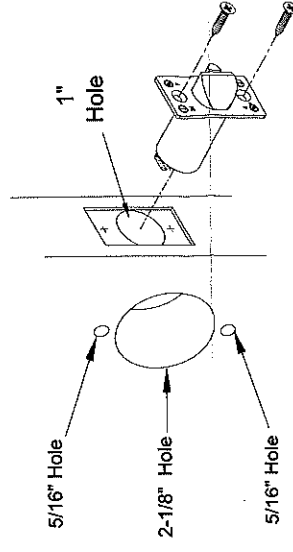

3. INSTALL STRIKE

- Use strike locating tool or pointed object to locate position for hole in frame.
- Bore 1" x 3/4" deep hole. Use strike as a template and mortise to the proper depth.
- If dust box is to be used, clear area with wood chisel.

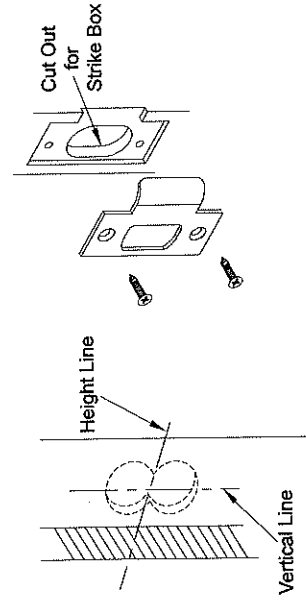

4. CHASSIS ADJUSTMENT

For door thickness adjustment:

- Remove Thru-bolt Retainer away from outer rose assembly.
- Rotate rose assembly to required position of door thickness.
- Move back Thru-bolt Retainer and mate with outer mounting plate.

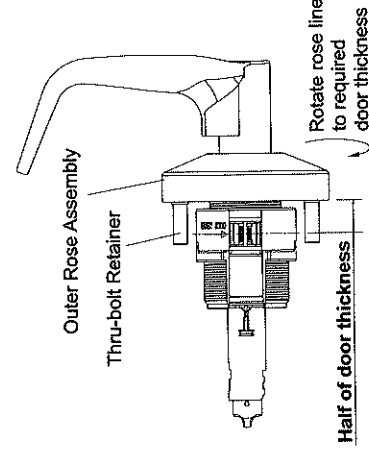

5. INSTALL OUTSIDE CHASSIS

- For ease of installation, lock should be in the unlocked position. (Figure 1)
- Slide chassis assembly into door from outside making sure that lock housing engages latch prongs, retractor must also engage latch bar. (Figure 2)

IMPORTANT: Chassis assembly must be positioned in center of door for proper operation.

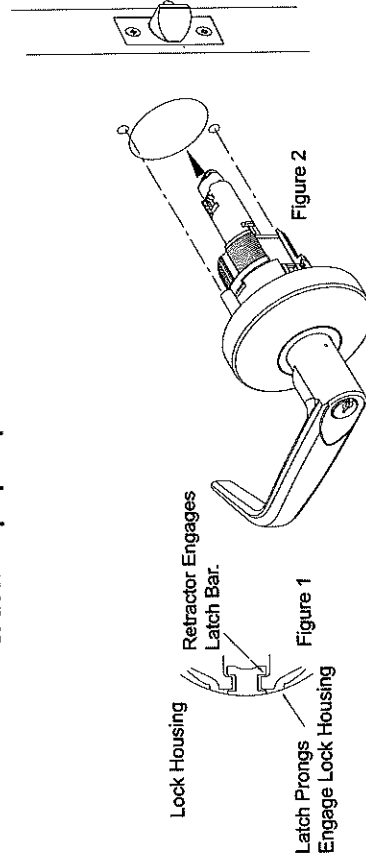

- Screw inside security mounting plate onto hub and tighten firmly by rotating plate with spanner wrench, adjust screw holes in plate to align with through bolts. (Figure 3)
- Insert screws and tighten. (Figure 4)

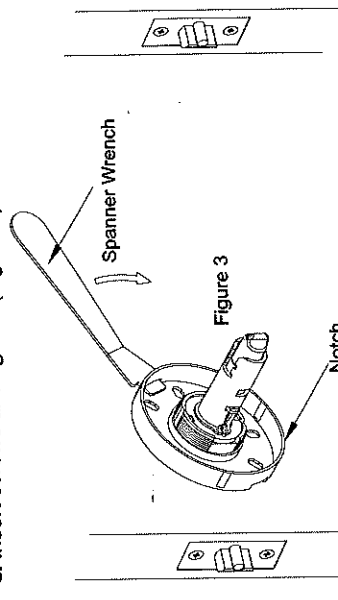

NOTE: Adjust either one of the notch in security mounting plate towards bottom.

CAUTION: Do not attempt to mount lock unit with door closed.

6. INSTALL INSIDE TRIM

- Locate the notch on edge of rose towards bottom and push in until flush with face of door.
- Align lever with spindle and push lever catch engages with hole.
- Check function before closing door.

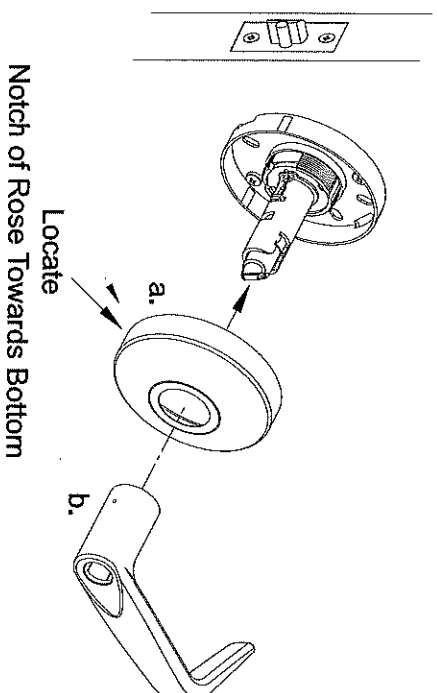

7. INSTRUCTIONS FOR REMOVING KEYED LEVERS

7.1 REMOVING LEVERS

- For Outside Levers Only: Turn key **45° clockwise** and hold.
- Depress lever catch and pull off lever and cylinder.

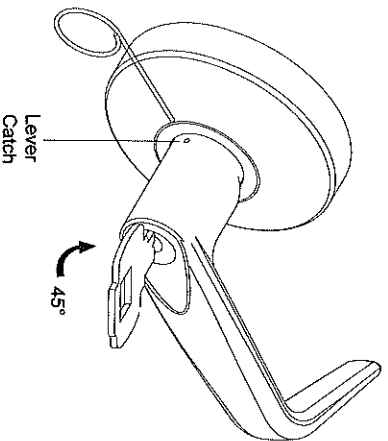

7.2 INSTALLING STANDARD CYLINDERS INTO LEVERS

- Attach a spacer on tailpiece.
- Insert cylinder into lever.
- Insert key into cylinder to hold and align cylinder.
- Put lever insert into lever to secure cylinder.

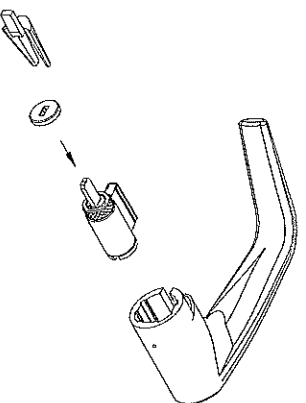

7.3 INSTALLING STANDARD CYLINDERS & LEVERS

- Align hole in lever with lever catch on spindle assembly and slide lever up to lever catch.
- For Outside Levers Only: Turn key or button **45° clockwise** and hold.
- Push lever in to engage lever catch.
- Check function before closing door.

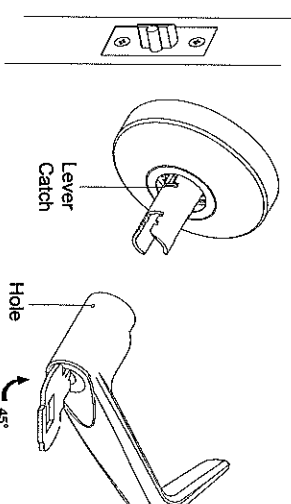

7.4 REMOVING IC CORE

- Unlock lockset.
- Turn control key **15° clockwise(CW)** or until key stops.
- Pull key to remove IC core.

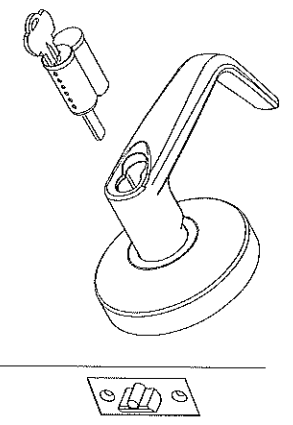

7.6 REMOVING IC LEVERS

- With IC core removed, using a screwdriver, depress lever catch and pull lever to remove.

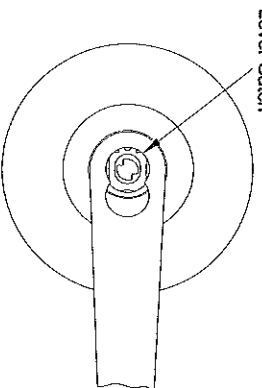

7.8 TAILPIECE INSTALLATION

- Insert spring and pin into cylinder.
- Place tailpiece into cap.
- Thread cap onto the cylinder.
- Attach a spacer on tailpiece.

NOTE: The cap must be properly adjusted. If too loose, excessive plug end play will prevent the key from being withdrawn. If too tight, the plug will drag and be difficult to rotate with the key.

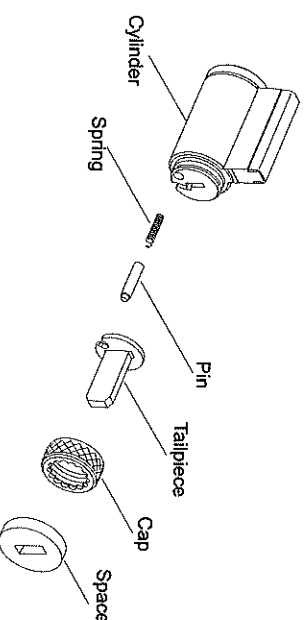

7.5 INSTALLING IC CORE

- With control key in core rotate key **15° clockwise** and insert fully into lever.
- Turn the key counter-clockwise and remove key.
- Check function before closing door.

7.7 INSTALLING IC LEVERS

- Push lever in until lever catch engages with lever.

7.9 CYLINDER TIMING

For Store Function:

- Install lock on door as shown in steps 1 thru 7.
- Using a 1/4" diameter philips screwdriver, turn key spindle until stop and lever is locked.
- Turn back the key spindle 1/2 turn.
- If IC go to g.. Remove standard cylinder lever.
- Insert cylinder into lever as shown in step 8.2.
- Insert lever and cylinder onto spindle and shown in step 8.3.
- For IC: Install IC lever into spindle as shown in step 8.7. Insert cylinder into lever as shown in step 8.5.
- Repeat a, thru g, for opposite side.
- Check operation:
Outside-turn key **CCW 270°** to unlock.
turn key **CW 180°** to lock.
- Inside -turn key **CCW 270°** to unlock.
turn key **CW 180°** to lock.

For Communicating & Classroom Function:

- Install lock on door as shown in steps 1 thru 7.
- Using a 1/4" diameter philips screwdriver, turn key spindle until stop and lever is locked.
- If IC go to g.. Remove standard cylinder lever.
- Insert cylinder into lever as shown in step 8.2.
- Slide lever and cylinder onto the spindle and push the cylinder in to engage the key spindle.
- Insert key into cylinder and turn **CW 45°**.
- For IC: Insert cylinder into lever as shown in step 8.4.
- Check operation:
Outside-turn key **CW 360°** to unlock.
turn key **CCW 360°** to lock.

This product is covered by one or more of the following patents: 4,725,086; 4,732,023; 4,744,232; 4,750,766; 4,756,178; 4,809,626; 4,838,053; 4,840,412; 4,840,413; 4,921,289; 4,930,822; 5,149,151; 5,177,987; 5,887,465; 5,983,683; 5,987,947; 6,041,630; 6,279,360; B1; 6,302,457; B1; 6,364,383; B1 and other patents pending.