

Installation Instructions

720B-DM

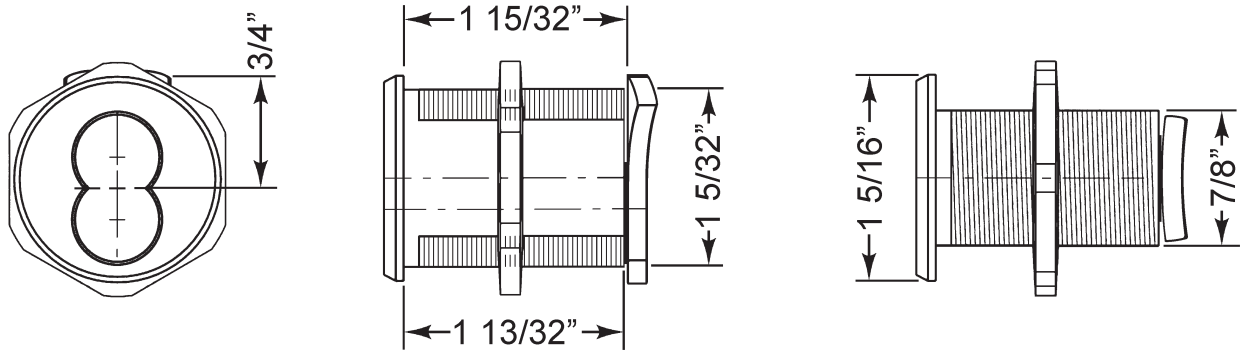

MOUNTING CUTOUT

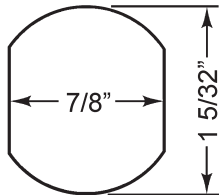

Lock diameter is 1-1/8".
Drilled hole should be slightly larger.

CL-MP-118

Double-D metal hole punch is available separately. Punches double-D cut out in metal. For use with 1-1/8" diameter cam locks.



Order part number
CL-MP-118

TYPICAL INSTALLATION

Depending on Distance "A" and your specific application, one or both of the supplied spacer collars may be required.

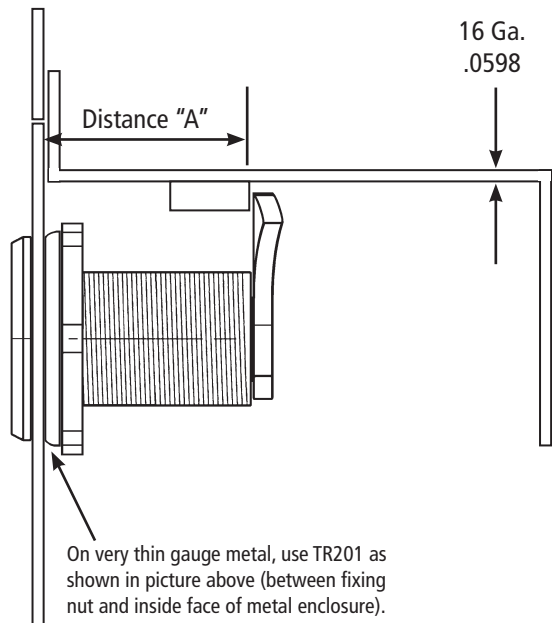

Title

Installation instructions for 720B-DM series cam lock

Series	Barrel Length	Bolt type	Mounting	Revision Date
720B-DM	1-7/16"	Cam lock	Surface	03/2015

