



## INSTALLATION INSTRUCTIONS FOR N (PASSAGE), F (STOREROOM), AB (ENTRY) AND T (CORRIDOR) FUNCTIONS

BEFORE INSTALLATION MEASURE DOOR THICKNESS. LOCK IS PRE-ASSEMBLED FOR 1 3/4" DOOR THICKNESS.  
IF DOOR THICKNESS VARIES FROM 1 3/4" FOLLOW ADJUSTMENT PROCEDURE ON BACK OF PAGE.

### INSTALL SECURE SIDE TRIM ASSEMBLY

- 1.) Align inside lever/rose assembly so rose posts enter thru-bolt holes in door.
- 2.) Push lock and trim assembly through 2-1/8" hole **FROM SECURE SIDE** of room so that retractor engages latch tail.
- 3.) Prongs must engage inside lock housing (Figure 1).
- 4.) Check from opposite side of door to ensure that latch is properly engaged.

### INSTALL OUTSIDE TRIM ASSEMBLY

- 1.) Slide rose assembly over tube, passing the spring-loaded lever catch.
- 2.) Fasten rose assembly with 2 mounting screws.
- 3.) Install plastic washer(s) between both lever and rose assemblies. Washers may be added or removed as needed to eliminate excess play from lever handle (additional thin white washers are included). When determining required washer thickness, ensure the lever properly engages lever catch and does not pull off. If lever has excessive play that cannot be removed through use of washers, follow adjustment procedure outlined on back of page. The black and white washers provided are different thicknesses, it may be necessary to use multiple washers of varying thickness (ex. 1 black and 1 white washer) to achieve desired lever operation.
- 4.) Turn key in cylinder 45° in either direction.
- 5.) Slide and push lever handle over tube until spring loaded lever catch is fully engaged.
- 6.) Remove key from cylinder then check lock for proper operation before closing door.

#### **NOTE: Key is non-functional in passage function**

- 7.) After lock is properly installed, adjusted and tested, remove lever on secure side and install security sleeve\* on rose.

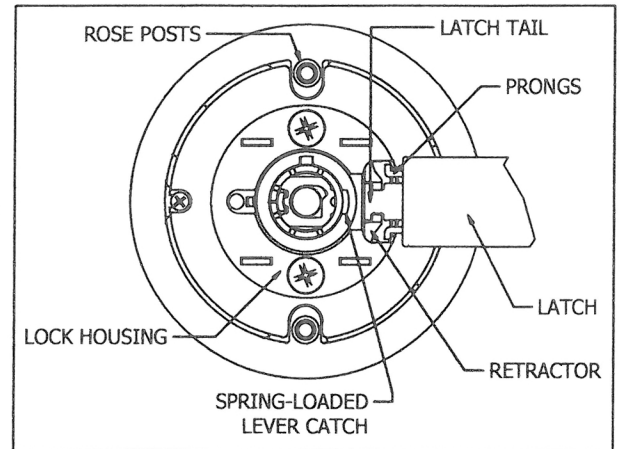
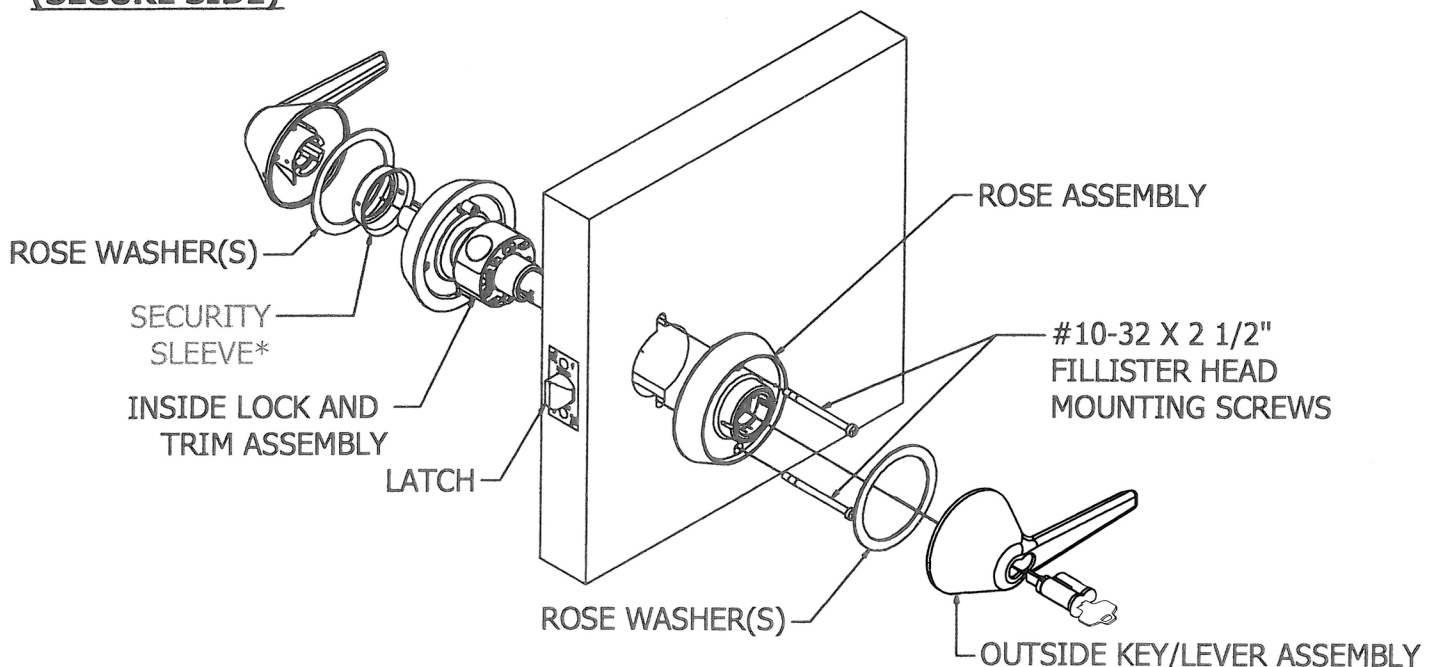

FIGURE 1

**\*NOTE: Once the security sleeve is installed, the lever handle cannot be removed. Failure to install security sleeve will result in a potential life threatening condition.**

### < INSIDE OF DOOR (SECURE SIDE)

### OUTSIDE OF DOOR >





## ADJUST LOCKSET

NOTE: ALL LOCKS COME PRE-ADJUSTED FOR 1 3/4" DOOR THICKNESS.

- 1.) Measure door thickness.
  - 2.) The distance from the mounting surface of the threaded rose to the centerline of the latch retractor must be equal to 1/2 door thickness (see Figure 2).  
[ex. for 1.750" door, distance to latch retractor centerline = 0.875"]
  - 3.) Remove lever from secure side.
  - 4.) While depressing spring-loaded lever catch, rotate rose (in or out) to adjust for door thickness
- NOTE: 1/2 rotation (180°) will move rose in/out by 0.020", 1 full rotation will move in/out 0.040"
- 5.) Follow instructions on reverse of page to complete lock set installation.

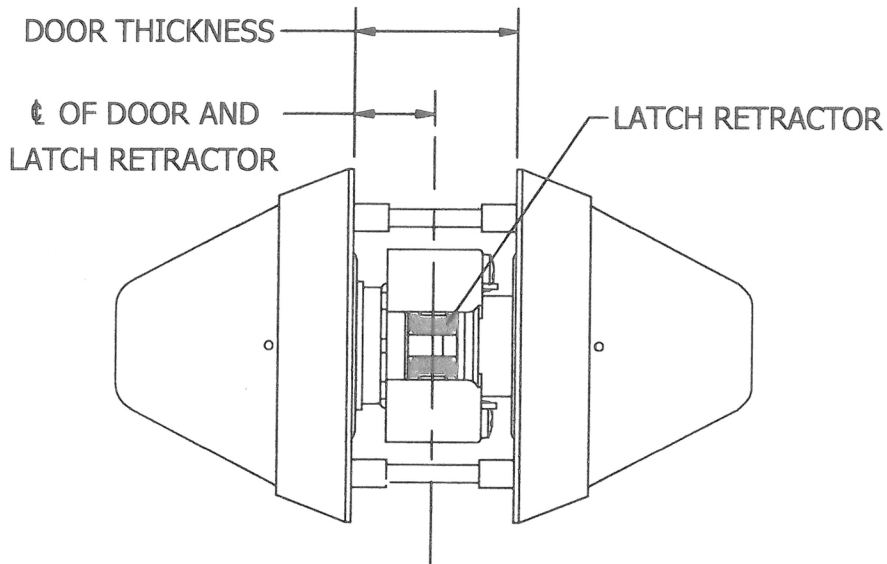

FIGURE 2

LOCK IS SUPPLIED WITH MULTIPLE WASHERS  
(DIFFERENT THICKNESSES - WHITE=THIN, BLACK=THICK)  
ADD OR REMOVE WASHERS TO ELIMINATE PLAY IN LEVERS.

INSTALL SECURE SIDE LEVER **WITHOUT** SECURITY SLEEVE TO  
DETERMINE CORRECT THICKNESS AND AMOUNT OF WASHERS USED.

ENSURE LEVER IS PROPERLY ENGAGED AFTER FINAL ASSEMBLY.  
IF WASHER(S) ARE TOO THICK, LEVER HANDLE WILL NOT ENGAGE KNOB CATCH.

SECURITY SLEEVE **MUST BE INSTALLED**  
ON SECURE SIDE (SIDE WITH THREADED ROSE) ONLY  
AFTER PROPER DOOR ADJUSTMENT.

LEVER CANNOT BE REMOVED ONCE  
SECURITY SLEEVE IS INSTALLED!

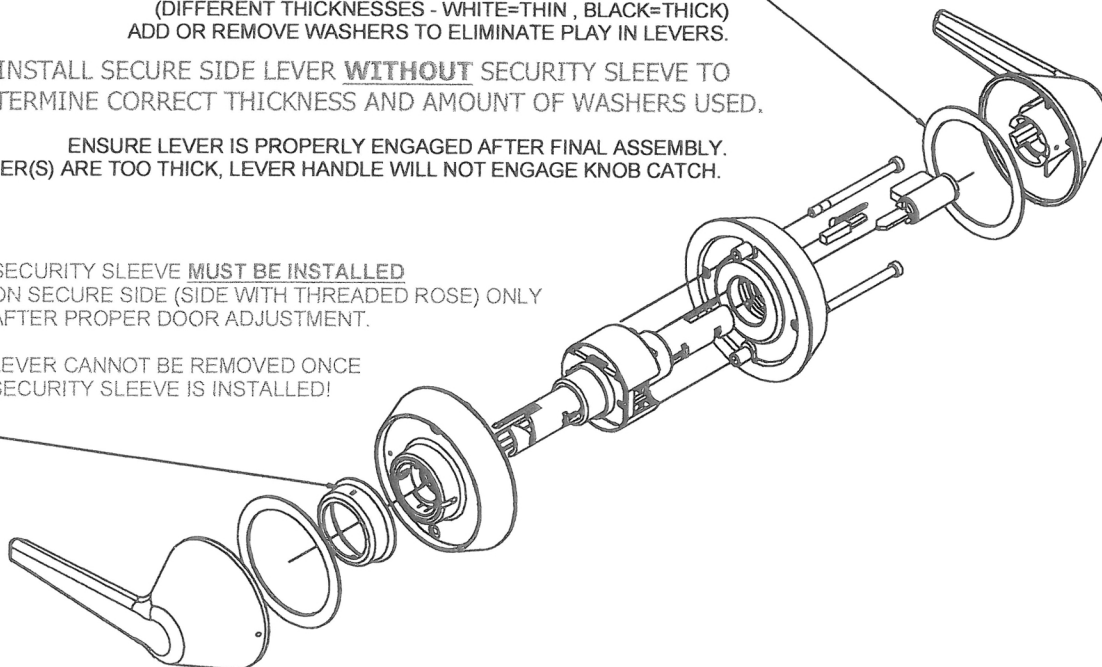

SECURE SIDE