

**2100 /F2100 SERIES  
RIM EXIT DEVICE**

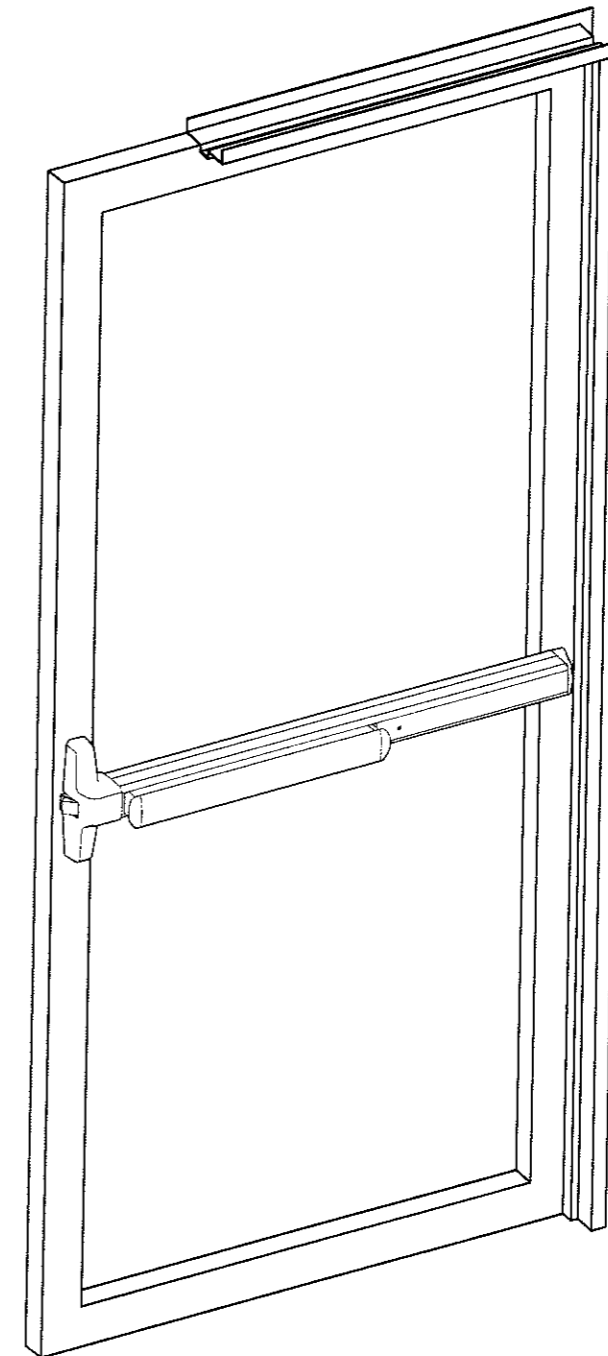

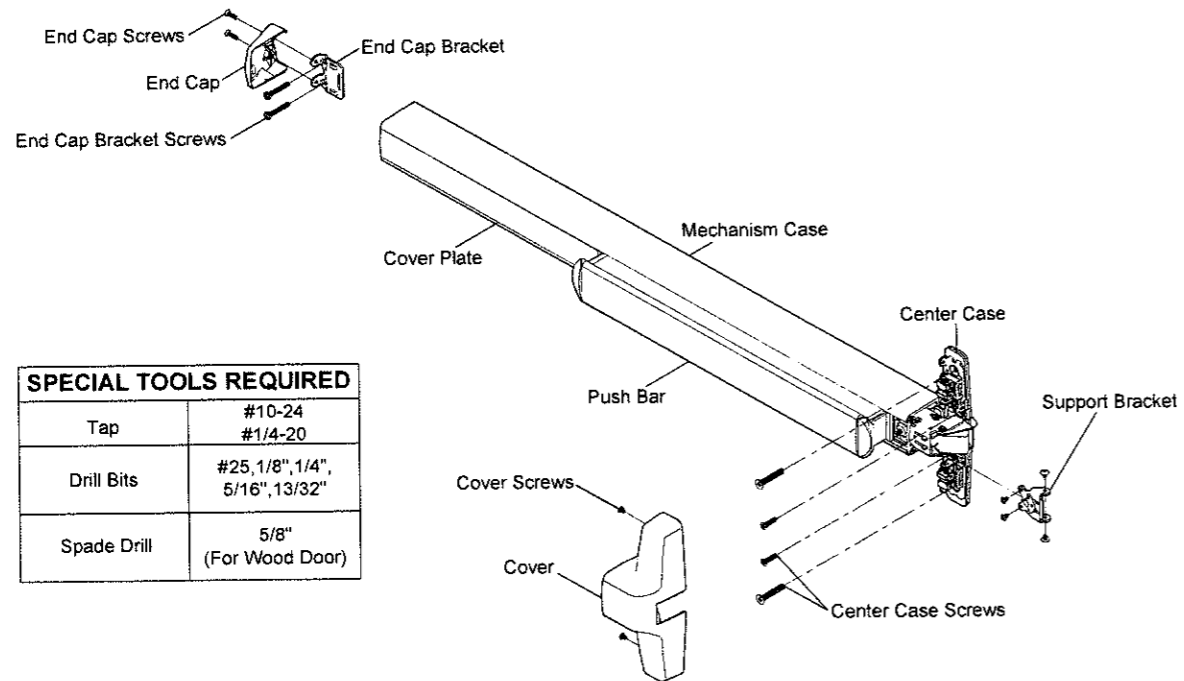







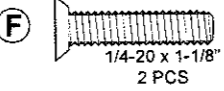
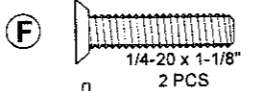
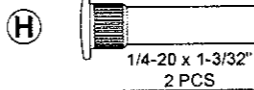
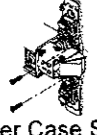
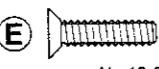
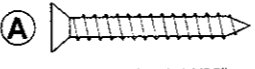

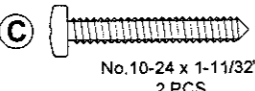
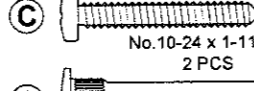
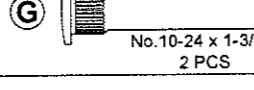
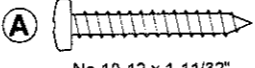

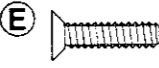
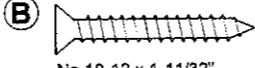
**INSTALLATION INSTRUCTIONS**

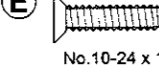
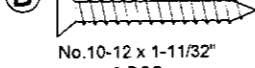

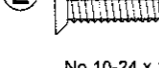
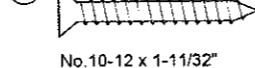

SPECIAL TOOLS REQUIRED	
Tap	#10-24 #1/4-20
Drill Bits	#25, 1/8", 1/4", 5/16", 13/32"
Spade Drill	5/8" (For Wood Door)

### SCREW CHART

LOCATION	METAL	SEX BOLTS	WOOD
 Center Case Screws	 F 1/4-20 x 1-1/8" 2 PCS	 F 1/4-20 x 1-1/8" 2 PCS  H 1/4-20 x 1-3/32" 2 PCS	Trim mount or sex bolts
 Center Case Screws	 E No. 10-24 x 11/16" 2 PCS		 A No. 10-12 x 1-11/32" 2 PCS
 End Cap Bracket Screws	 C No. 10-24 x 1-11/32" 2 PCS	 C No. 10-24 x 1-11/32" 2 PCS  G No. 10-24 x 1-3/32" 2 PCS	 A No. 10-12 x 1-11/32" 2 PCS
 103 Strike Screws	 E No. 10-24 x 11/16" 4 PCS		 B No. 10-12 x 1-11/32" 4 PCS
 106 Strike Screws	 E No. 10-24 x 11/16" 3 PCS		 B No. 10-12 x 1-11/32" 3 PCS
 108 Strike Screws	 E No. 10-24 x 11/16" 7 PCS		 B No. 10-12 x 1-11/32" 7 PCS
 End Cap Screws	 J	 No. 8-32 x 5/8" 2 PCS	
 Cover Screws	 I	 No. 8-32 x 5/32" 2 PCS	

# 2100 2200 2500 DEVICE TEMPLATE

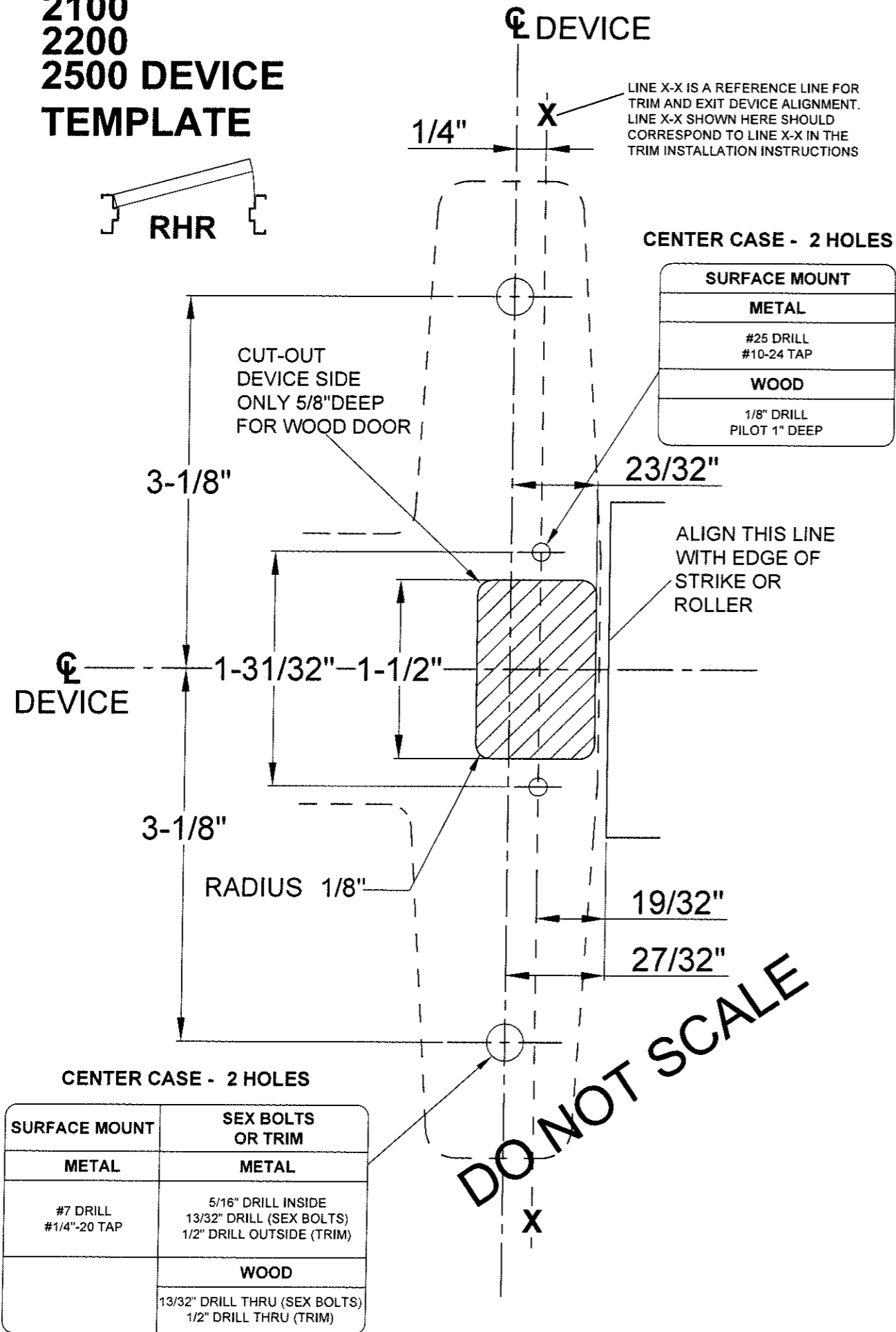

# DOOR PREPARATION CHART

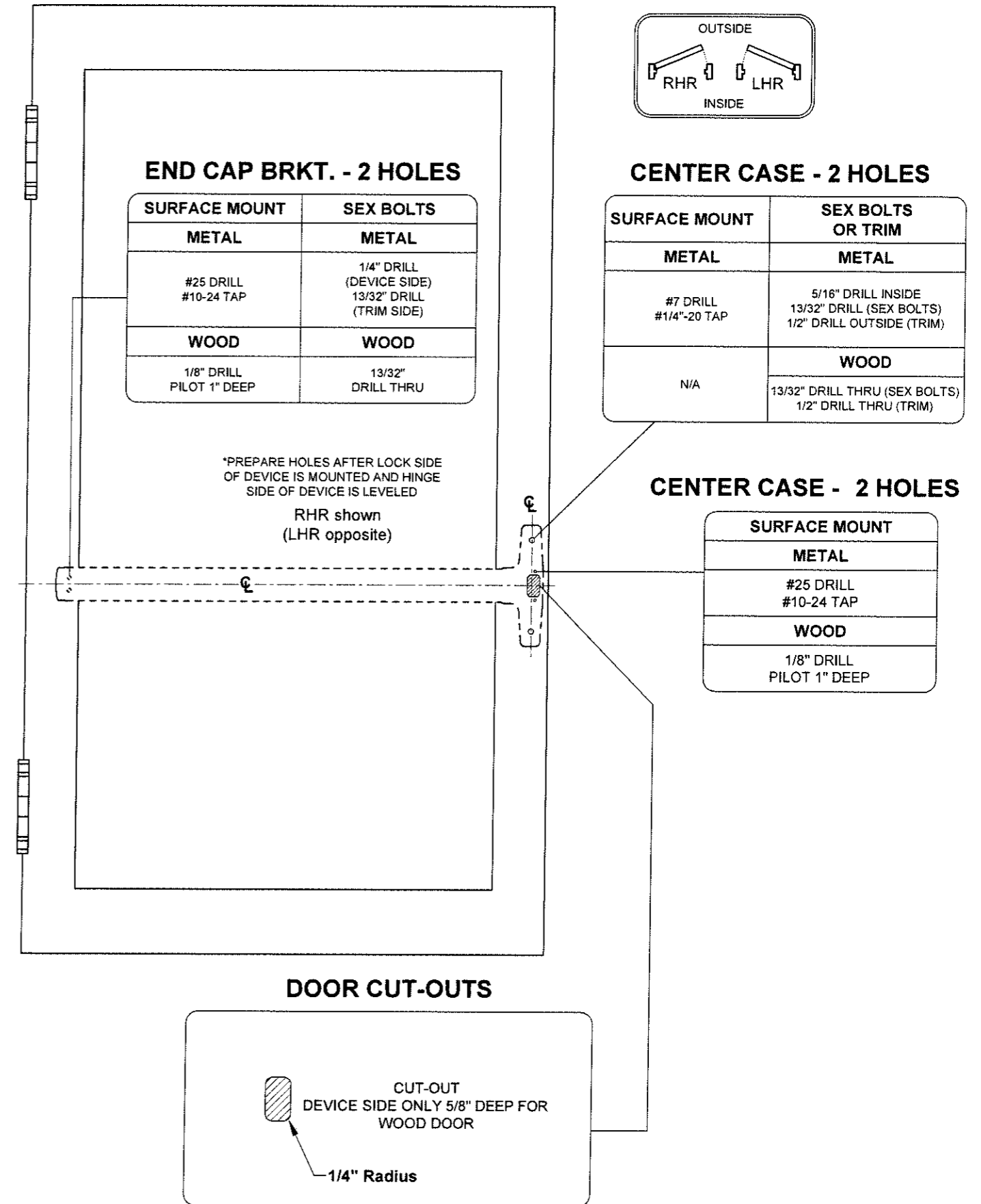

**1 DRAW HORIZONTAL DEVICE AND STRIKE CENTERLINE.**

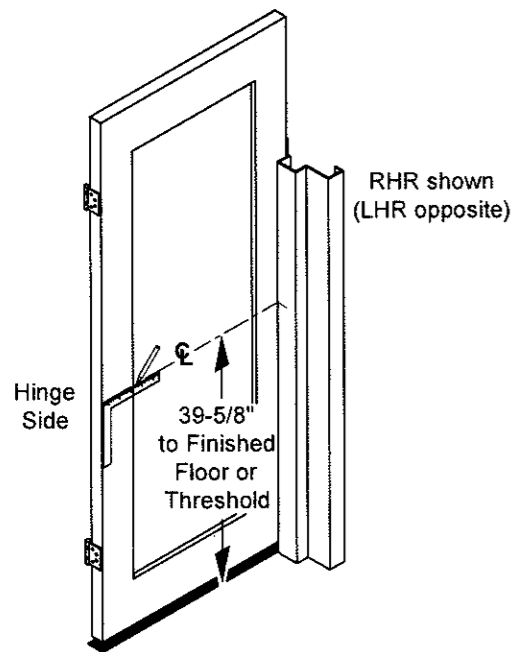

Close door, mark horizontal centerline on inner side of door and on door stop. The distance of centerline measured from finished floor should be of 39-5/8". If trim is used, horizontal centerline should be measured on outer side of door as well.

**5 PREPARE DOOR FOR DEVICE AND TRIM.**

See trim instructions for outside door preparation. Locate same vertical centerline for both sides. Be extra careful if edge of door is beveled. Be sure X-X vertical centerline is parallel to edge of door.

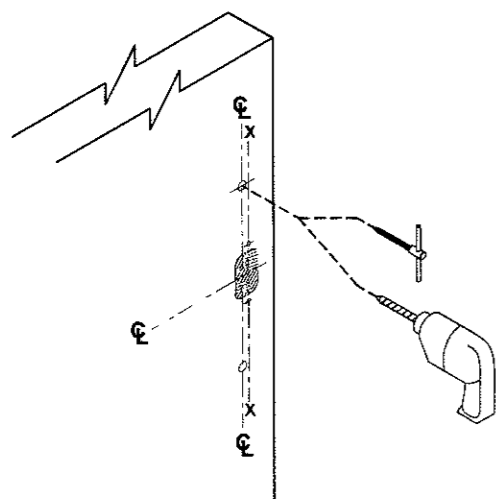

See "DOOR PREPARATION CHART" on page 3 for drill, tap and cut-out information.

**2 ALIGN STRIKE ON HORIZONTAL CENTERLINE (C) AND MARK TWO(2) SLOTTED HOLES.**

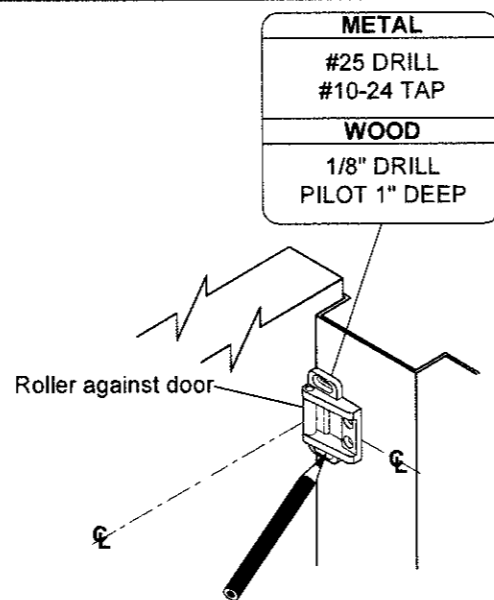

Use strike as template and place it against inner side of door and door stop such that strike is aligned both with centerlines on door and on stop. Mark centers and drill / tap holes as required.

**6 MEASURE TO DETERMINE LENGTH TO CUT DEVICE**

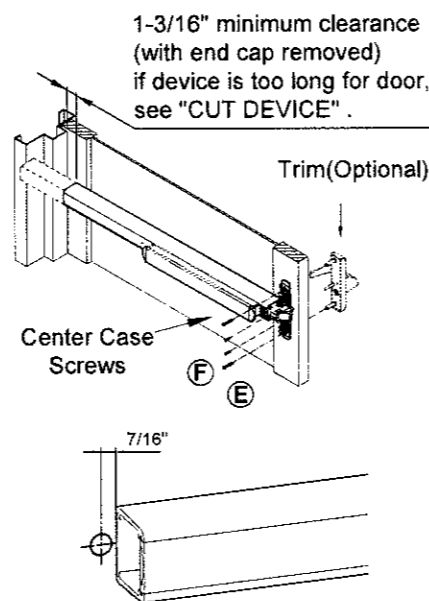

If 5/8" diameter wire access hole has been predrilled in door, cut device 7/16" measured from center of hole.

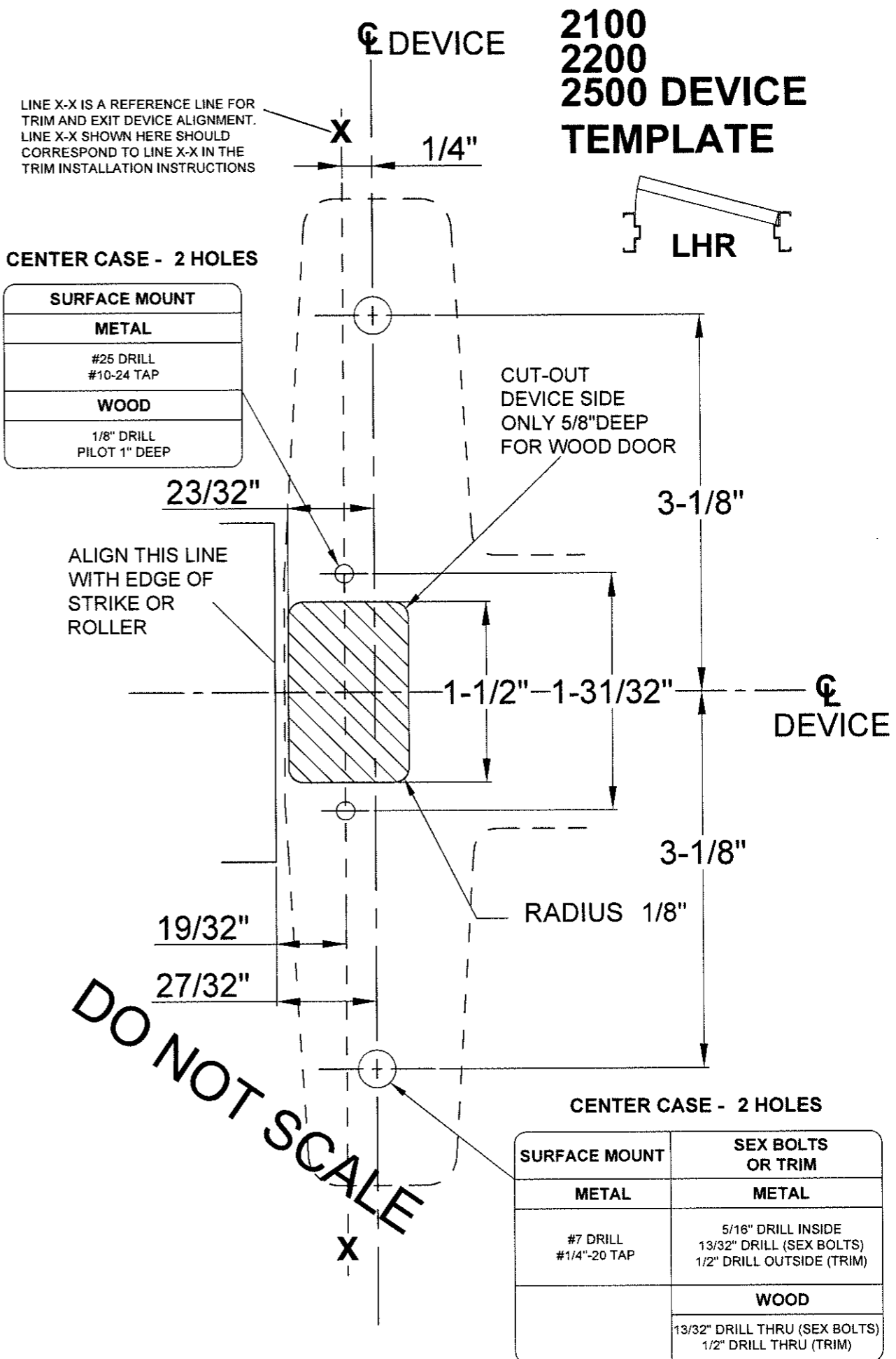

# 108 STRIKE INSTALLATION

## 1 PREPARE AND INSTALL SCREWS THROUGH 2 STRIKE SLOTS.

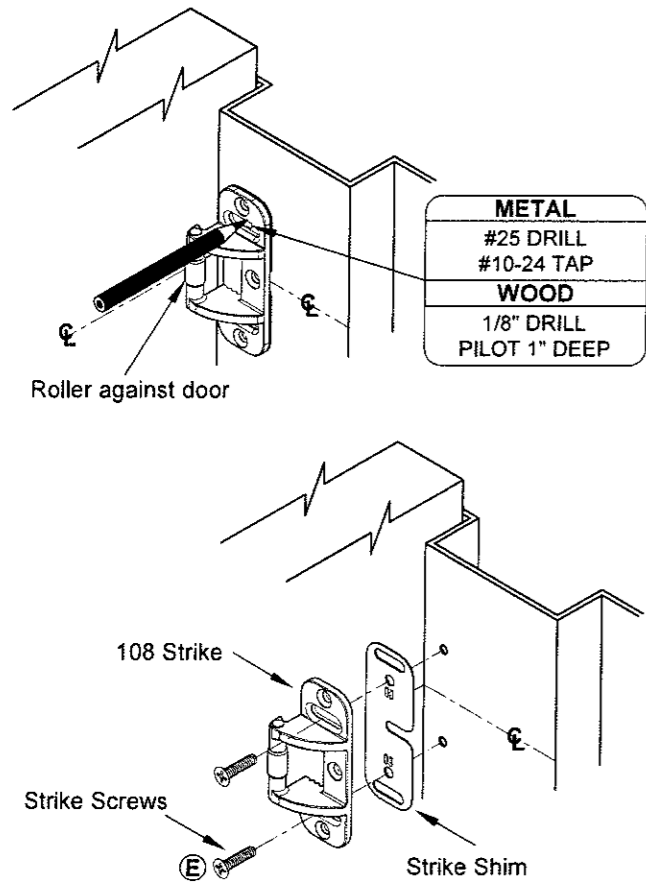

## 2 INSTALL STRIKE HOOK AND ADDITIONAL STRIKE SCREWS.

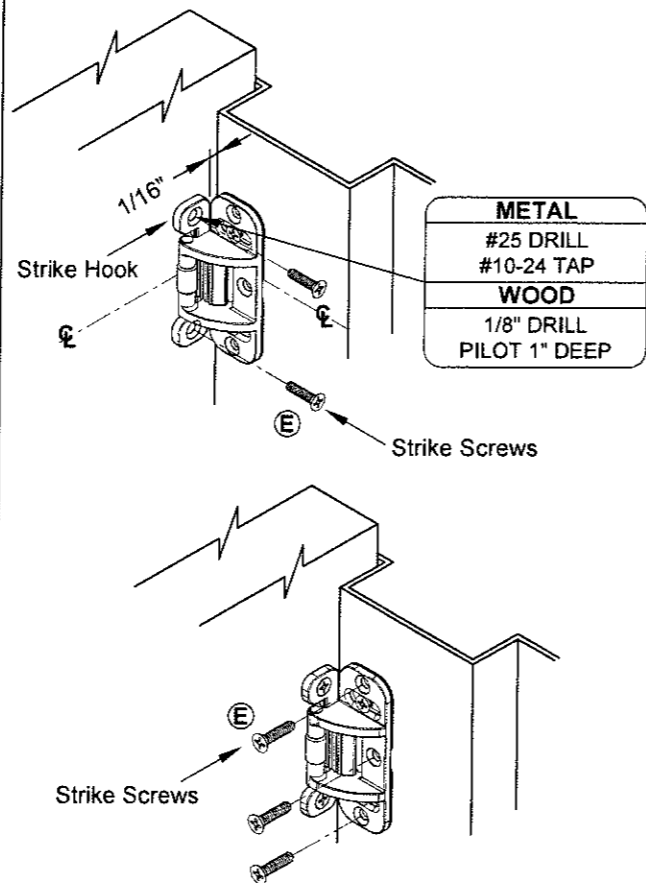

## 3 TEMPLATE ALIGNS AS SHOWN.

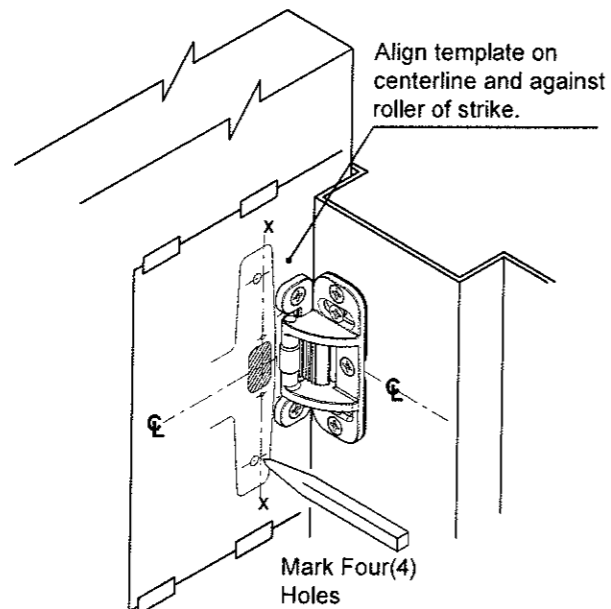

## 3 INSTALL STRIKE AND SHIM.

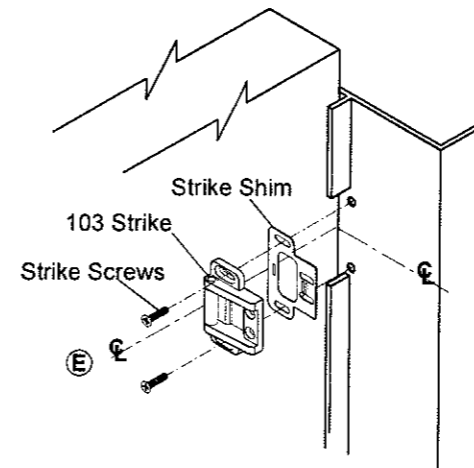

Prepare two(2) holes and install a screw through each slot.

For 106 and 108 strikes, refer to page 7 and page 8 of this instruction manual.

## 7 CUT DEVICE (IF REQUIRED)

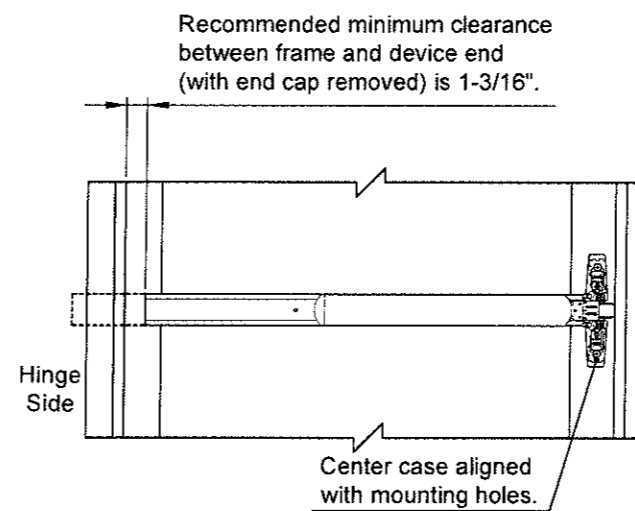

## 4 POSITION TEMPLATE AGAINST STRIKE AND ON E AND MARK DOOR.

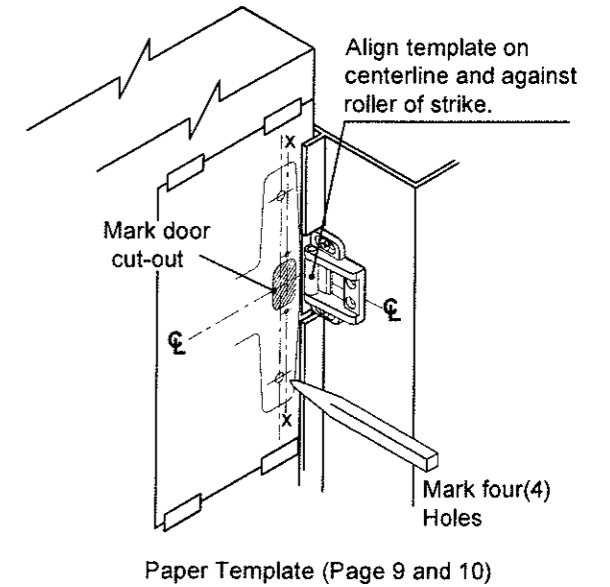

Position and tape template (and trim template if trim is used), making sure the centerlines of the template and door are aligned, as show in above figure. Mark centers and drill / tap the required holes as indicated on the template.

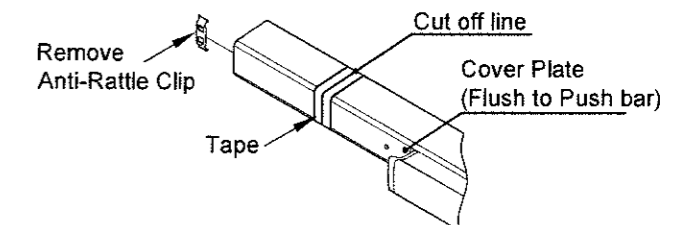

1. With anti-rattle clip removed, tape and mark area being cut.

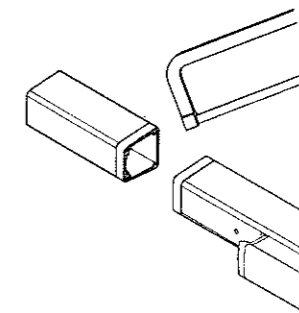

2. Cut off device and deburr. **NOTE:** Device must be cut square for proper end cap fit.

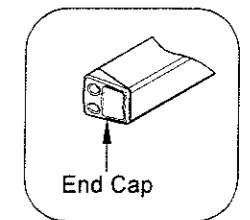

## 8 INSTALL MOUNTING BRACKET AND END CAP.

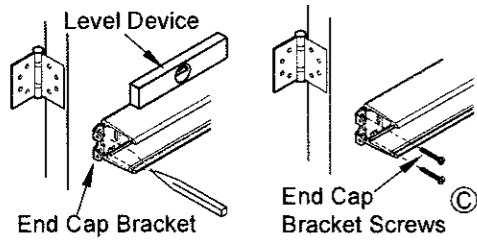

1. Remove cover plate, insert end cap bracket into push bar assembly against mechanism case. Level device, mark and drill two(2) holes for Bracket Screws. Fasten end cap bracket screws to door.

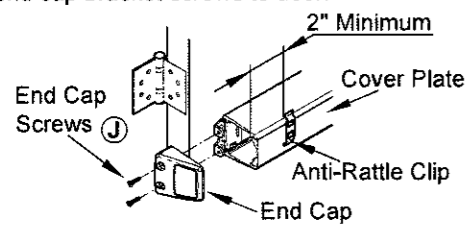

2. Insert cover plate, slide anti-rattle clip in position (2" minimum from end), and attach end cap with two(2) end cap screws.

## 9 ADJUST AND SECURE STRIKE.

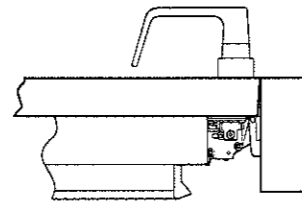

Fasten strike to frame and adjust strike so that the device latches tightly without binding, apply center screw once adjustment is complete.

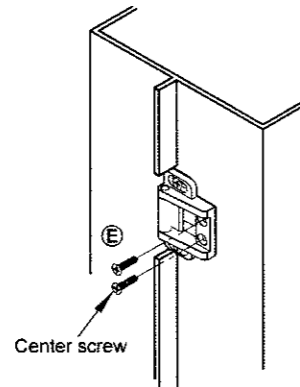

## 10 INSTALL COVER.

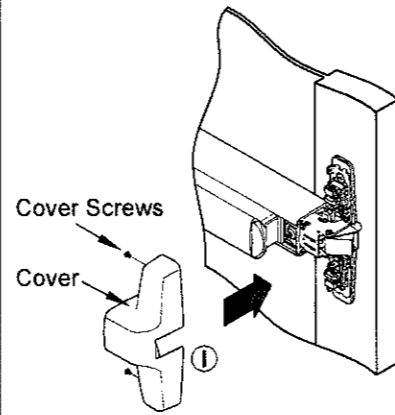

Attach cover to center case with two(2) center case screws.

## 106 STRIKE INSTALLATION

### 1 ALIGN STRIKE ON HORIZONTAL CENTERLINE (C) AND MARK TWO(2) SLOTTED HOLES.

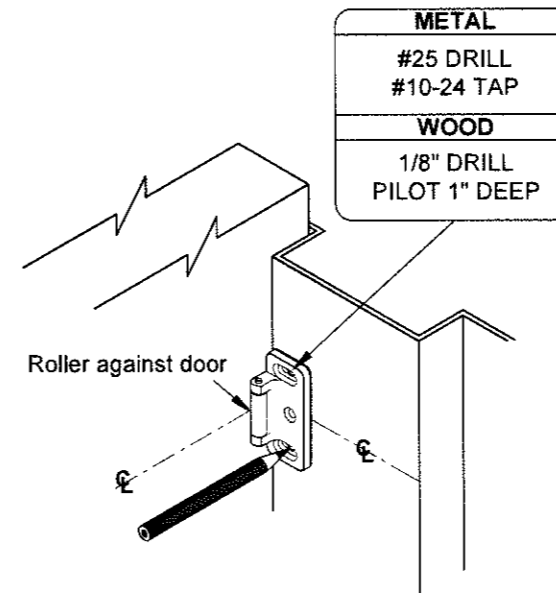

Use strike as template and place on door stop and against inside face of door, so the horizontal centerline on strike lines up with the horizontal centerline on door stop and door. Mark centers and drill / tap holes as required.

### 2 INSTALL STRIKE AND SHIM.

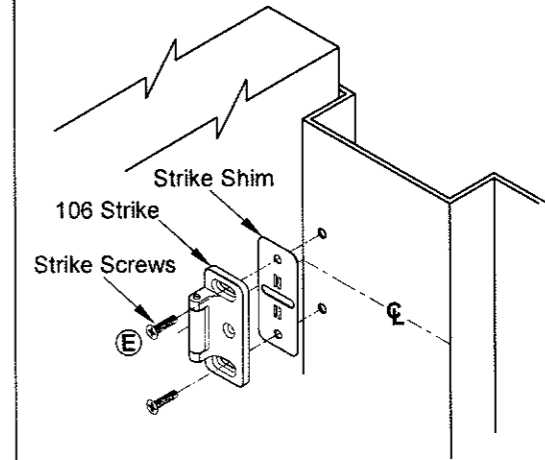

Prepare two(2) holes and install a screw through each slot.

For 108 strike see back cover of this page.

## OPTIONAL DOGGING

### CYLINDER DOGGING

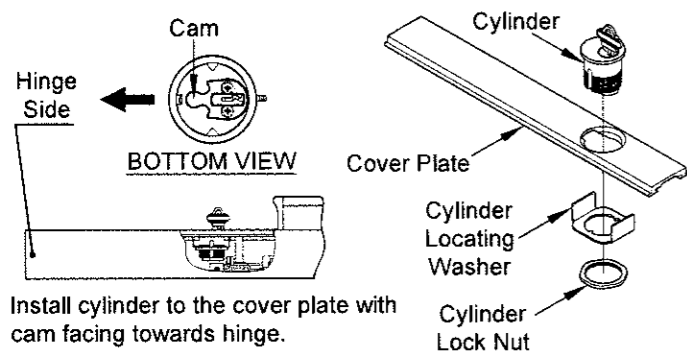

Install cylinder to the cover plate with cam facing towards hinge.

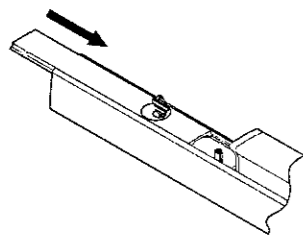

Slide cover plate in position in the mechanism case.

### DOGGING CHECK

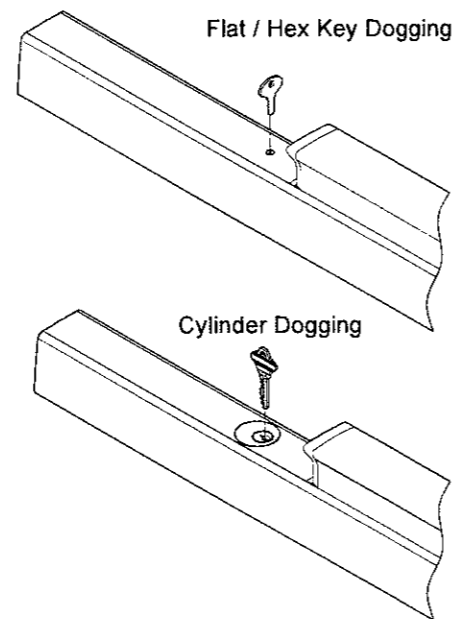

Depress push bar and turn flat / hex wrench or key one full turn for dogging check.

### 3 TEMPLATE ALIGNS AS SHOW

